



LANDSAT 7 SYSTEM

DATA FORMAT CONTROL BOOK (DFCB) VOLUME IV – WIDEBAND DATA

**11 June 1999
Revision L**

Contract No. NAS5-32633

Prepared for:

**NASA/Goddard Space Flight Center
Landsat Project Office
Code 430
Greenbelt, MD 20771**

Prepared by:

**Lockheed Martin Missiles & Space
P.O. Box 8555
Philadelphia, PA 19101**

23007702-IV-L
11 June 1999
Revision L



**DATA FORMAT CONTROL BOOK (DFCB)
VOLUME IV – WIDEBAND DATA
FOR
LANDSAT 7 SYSTEM**

CONTRACT NO. NAS5-32633

Prepared for:

**NASA/Goddard Space Flight Center
Landsat Project Office
Code 430
Greenbelt, MD 20771**

Prepared by:

[CAGE Code: 79272]

Al Kitto

**Lockheed Martin Missiles & Space
P.O. Box 8555
Philadelphia, PA 19101**

CHANGE STATUS LOG

DOCUMENT NO. 23007702-IV-LTITLE: DATA FORMAT CONTROL BOOK (DFCB) VOLUME IV - WIDEBAND DATA

REV	DATE	AFFECTED PAGES	REMARKS
	26 AUG '94	ALL	BASELINE
A	2 DEC '94	v, 1-1, 3-1, 3-3, 3-6, 3-7, 3-8, 3-10, 3-17, 3-20, 3-21, 3-26	REVISION A
B	15 MAY '95	2-1, 3-1, 3-2, 3-3, 3-4, 3-6, 3-7, 3-8, 3-9, 3-10, 3-11, 3-12, 3-14, 3-15, 3-16, 3-17, 3-18, 3-19, 3-20, 3-21, 3-22, 3-23, 3-24, 3-25, 3-26, 3-27, 3-28, 3-29, 3-30, 3-31, 3-32, 3-33, 3-34, 3-35, 3-36, 3-37, 3-38, 3-39, 3-43, 3-44, 3-45, 3-47, 4-48, 3-49, 3-50, A-1, A-2	REVISION B
C	4 APR '96	ALL	REVISION C
D	11 FEB '97	3-2, 3-3, 3-5, 3-6, 3-11, 3-13, 3-15, 3-16, 3-17, 3-18, 3-19, 3-20, 3-21, 3-22, 3-28, 3-37, 3-38	REVISION D - INCORPORATES CHANGES PER ECN LS72183
E	15 MAY '97	3-15, 3-27, 3-35	REVISION E - INCORPORATES CHANGES PER ECN LS72183
F	29 MAY '97	3-7, 3-15, 3-17, 3-27	REVISION F - INCORPORATES CHANGES PER ECN LS2204
G	11 SEP '97	3-10	REVISION G - INCORPORATES CHANGES PER ECN LS72275
H	26 FEB '98	3-10, 3-11, 3-16, 3-18, 3-19, 3-20, 3-23 3-28 AND 3-29	REVISION H INCORPORATES CHANGES PER ENC LS72353
J	8 OCT '98	3-3, 3-9, 3-11, 3-20 thru 3-23, 3-25, 3-27, 3-37, 3-38, 3-41, 3-42, 3-43, 3-44, 3-46, A-1, C-1 thru C-28	REVISION J INCORPORATES CHANGES PER ENC LS72443
K	16 DEC '98	3-2, 3-26, 3-27, and 3-47	REVISION K INCORPORATES CHANGES PER ENC LS72459
L	11 JUN '99	3-25, 3-26, 3-27, 3-29, 3-30, 3-38, 3-41, 3-42, 4-44, 4-46	REVISION L INCORPORATES CHANGES PER ENC LS72502

TABLE OF CONTENTS

<i>Section</i>	<i>Title</i>	<i>Page</i>
1	<i>SCOPE</i>	1-1
1.1	Identification	1-1
1.2	System Overview	1-1
2	<i>APPLICABLE DOCUMENTS</i>	2-1
2.1	Government Documents	2-1
2.2	Non-Government Documents	2-1
3	<i>IMPLEMENTATION</i>	3-1
3.1	Wideband Mission Data Protocol	3-1
3.1.1	Mission Data Layer	3-2
3.1.2	Virtual Channel Layer	3-2
3.1.2.1	Virtual Channel Link Control Sublayer	3-3
3.1.2.2	Virtual Channel Access Sublayer	3-5
3.1.2.3	Physical Channel Access Sublayer	3-8
3.1.3	Physical Channel Layer	3-8
3.2	ETM+ Mission Data Formats	3-8
3.2.1	ETM+ Data Flow and Formatting	3-9
3.2.2	Focal Plane, Spectral Bands, IFOV Size, and Ground Resolution	3-9
3.2.3	ETM+ Major Frame Structure	3-10
3.2.4	Minor Frame Data Structure	3-11
3.2.5	Minor Frame Formats	3-11
3.2.5.1	Line Sync Code Format (Scan Line Start)	3-11
3.2.5.2	Time Code Data Format	3-12
3.2.5.3	Scene Data Formats	3-13
3.2.5.4	End of Line Pattern Code Format	3-14
3.2.5.5	Scan Line Length/Direction Data	3-14

TABLE OF CONTENTS (CONT)

<i>Section</i>	<i>Title</i>	<i>Page</i>
	3.2.5.6 Calibration Data	3-17
	3.2.5.7 Fill Code Format	3-21
3.2.6	PCD/Status Data	3-21
	3.2.6.1 Status Data Words	3-21
	3.2.6.2 The Data PNTR	3-22
3.2.7	PCD Formats	3-25
	3.2.7.1 Unpacked PCD Format	3-25
	3.2.7.2 Packed PCD Format	3-26
	3.2.7.3 PCD Minor Frame	3-26
	3.2.7.4 PCD Data Types	3-26
	3.2.7.5 Subcommutation Word 72	3-38
3.3	Solid State Recorder	3-57
	3.3.1 Functional Architecture	3-57
	3.3.2 Record Format	3-57
	3.3.3 Playback Format	3-57
 <i>Appendix</i>		
A	ACRONYM LIST	A-1
B	REED-SOLOMON CODING	B-1
C	PAYLOAD CORRECTION DATA (PCD) LATENCIES	C-1

LIST OF ILLUSTRATIONS

<i>Number</i>	<i>Title</i>	<i>Page</i>
1	L7 Protocol Layering Relationships	3-1
2	L7 Wideband Protocol Layers	3-2
3	VCLC Sublayer	3-3
4	Data Pointer Bit Field Definition	3-3
5	Data Pointer Error Control Bit Field Definition	3-4
6	Mission Data Error Control BCH Code Block Relationships	3-5
7	BCH Encoding	3-6
8	VCDU Primary Header	3-6
9	Channel Access Data Unit Description	3-8
10	ETM+ Data Flow and Formatting	3-9
11	Focal Plane Layouts Projected Onto Earth Surface	3-10
12	ETM+ Major Frame, Minor Frames, CADU	3-11
13	Minor Frame Data Structure	3-12
14	Scene Data Format 1	3-14
15	Scene Data Format 2	3-15
16	Major Frame Events (Reverse Scan)	3-18
17	Major Frame Events (Forward Scan)	3-19
18	Unpacked PCD Format and Timeline	3-25
19	ETM+ PCD Major Frame Format	3-27
20	PCD Gyro Data	3-30
21	Gyro Drift Data	3-31
22	Attitude Estimate	3-31
23	SCP Representation of a 48-bit Extended Floating Point Word	3-32
24	PCD Ephemeris Data	3-34
25	PCD Subcommutation Major Frame (0) Word 72	3-42
26	PCD Subcommutation Major Frame (1) Word 72	3-46
27	PCD Subcommutation Major Frame (2) Word 72	3-52
28	PCD Subcommutation Major Frame (3) Word 72	3-56
29	Solid State Recorder Functional Architecture	3-57
30	Record Format Example	3-58
31	Playback Format Example	3-58

LIST OF TABLES

<i>Number</i>	<i>Title</i>	<i>Page</i>
1	Line Sync Code LSC Format (1 Minor Frame)	3-12
2	Time Code Data Format (6 Minor Frames)	3-13
3	Scene Data Formats	3-13
4	End of Line Pattern Code (1 of 2 Minor Frames)	3-14
5A	SAM Mode Scan Line Data (2 Minor Frames)	3-16
5B	Bumper Mode Scan Line Data (2 Minor Frames)	3-16
6	Band to A/D Converter Assignments	3-18
7	Data Format	3-20
8	Fill Code (1 Minor Frame)	3-20
9-1	PCD/Status Data	3-22
9-2	Comparisons of Synchronization Methods	3-23
10-1	PCD Typical Minor Frame	3-28
10-2	PCD Minor Frame Sync Format	3-29
10-3	PCD Minor Frame Identifier	3-29
11	ADS/PDF Temperature	3-30
12	PCD Time Code	3-35
13	PDF Ground Reference Telemetry	3-36
14	PCD Major Frame Identifier	3-36
15	Attitude Control System Modes	3-36
16	Gyro Select Bit Codings	3-37
17	ETM+ Major Frame (0) Word 72	3-39
18	ETM+ Major Frame (1) Word 72	3-43
19	ETM+ Major Frame (2) Word 72	3-47
20	ETM+ Major Frame (3) Word 72	3-53

SECTION 1 SCOPE

1.1 IDENTIFICATION

This volume defines the formats used for the transmission of Landsat 7 wideband data to the Ground Segment and to the International Ground Stations.

1.2 SYSTEM OVERVIEW

The Wideband Mission Data consists of all Enhanced Thematic Mapper Plus (ETM+) instrument data with embedded Payload Correction Data (PCD). The PCD is the ancillary spacecraft data needed to properly process the ETM+ image data, and is provided to the ETM+ by the satellite Command and Data Handling Subsystem. The Wideband ETM+ data is transmitted to the ground station at Sioux Falls, South Dakota or to the International Ground Stations (IGS) in real-time or subsequent playback from solid state recorders using 3 X-Band antennas. One of the three X-Band antennas can transmit data over one, two, or three frequencies at a rate of 150 Mbps per frequency. The second transmits over one or two frequencies. The third X-Band antenna operates at a single frequency with a rate of 150 Mbps.

SECTION 2 APPLICABLE DOCUMENTS

2.1 GOVERNMENT DOCUMENTS

The following documents of the exact issue shown, form a part of this specification to the extent specified herein. In the event of a conflict between the documents referenced herein and this document, the contents of this document shall be considered a superseding requirement.

Specifications:

MIL-STD-1750 Military Standard, Sixteen-Bit Computer Instruction Set Architecture

2.2 NON-GOVERNMENT DOCUMENTS

The following documents, of the exact issue shown where listed or the latest approved issue where not listed, form a part of this document to the extent specified herein. In the event of a conflict between the documents referenced herein and this document, the contents of this document shall be considered a superseding requirement.

Specifications:

PS230020620 Critical Item Product Function Specification for the Landsat 7 Payload
7 July 1995 Data Formatter

Standards:

CCSDS 701.0-B-1 Advanced Orbiting Systems, Networks and
Issue 1 Data Links: Architectural Specification
October 1989

CCSDS 101.0-B-3 Telemetry Channel Coding
May 1992

Other Publications:

PS23007610 Program Coordinates System Standard

SECTION 3 IMPLEMENTATION

3.1 WIDEBAND MISSION DATA PROTOCOL

The Landsat 7 System requirements specify that all space to ground data transfers utilize the Consultative Committee for Space Data Systems (CCSDS) telecommand and telemetry recommendations. The CCSDS protocol that will be used on Landsat 7 can be divided into three layers. The three layers in the data structure roughly correspond to the Open System Interconnection (OSI) reference model as shown below in Figure 1. They are:

1. The Application Data Layer which consists of the actual mission data and associated Error Detection and Correction (EDAC) codes.
2. The Virtual Channel Layer which consists of CCSDS headers and trailers required for end-to-end flow and error control, and synchronization markers.
3. The Physical Channel Layer which is responsible for transmission of the data across a physical medium; in the case of Landsat 7 the medium is a QPSK modulated X-band radio channel.

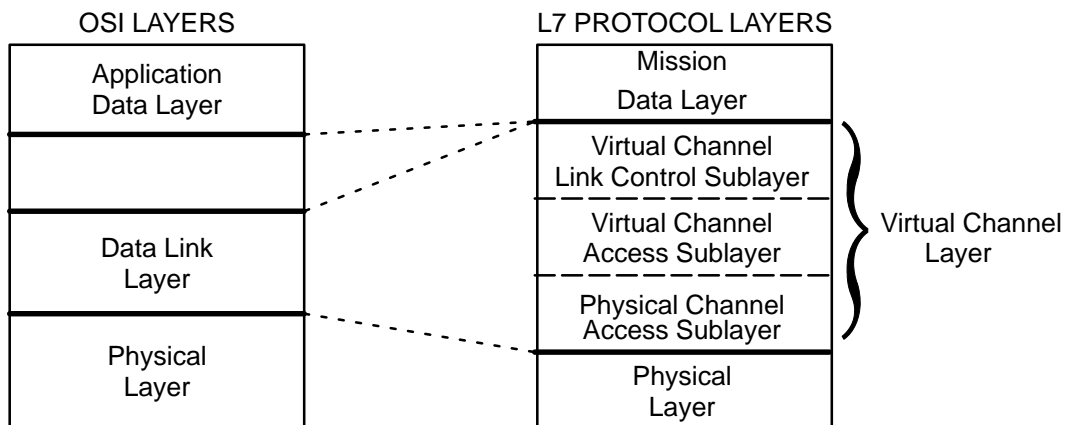

Figure 1. L7 Protocol Layering Relationships

The wideband communications protocol structure is compliant with a CCSDS Grade 3 Bitstream service (see Figure 2.) The application or mission data is delivered to the protocol function in a bitwise serial (bitstream) manner at the Virtual Channel Link Control (VCLC) sublayer. A Landsat 7 unique data pointer is inserted to provide the end user the ability to accurately reconstruct the data stream. Additionally, a BCH EDAC field is added to achieve the required BER of 10^{-6} . From a protocol perspective, the BCH EDAC field can be considered part of the data field.

The data stream is subsequently fed into the Virtual Channel Access (VCA) sublayer where the appropriate headers and trailers are appended to provide for end-to-end flow control. The result of this process is the creation of a Virtual Channel Data Unit (VCDU). Just prior to transmission on the Physical Channel, a synchronization header is added to create a Channel Access Data Unit (CADU). Finally, the data stream is modulated and transmitted over the physical channel.

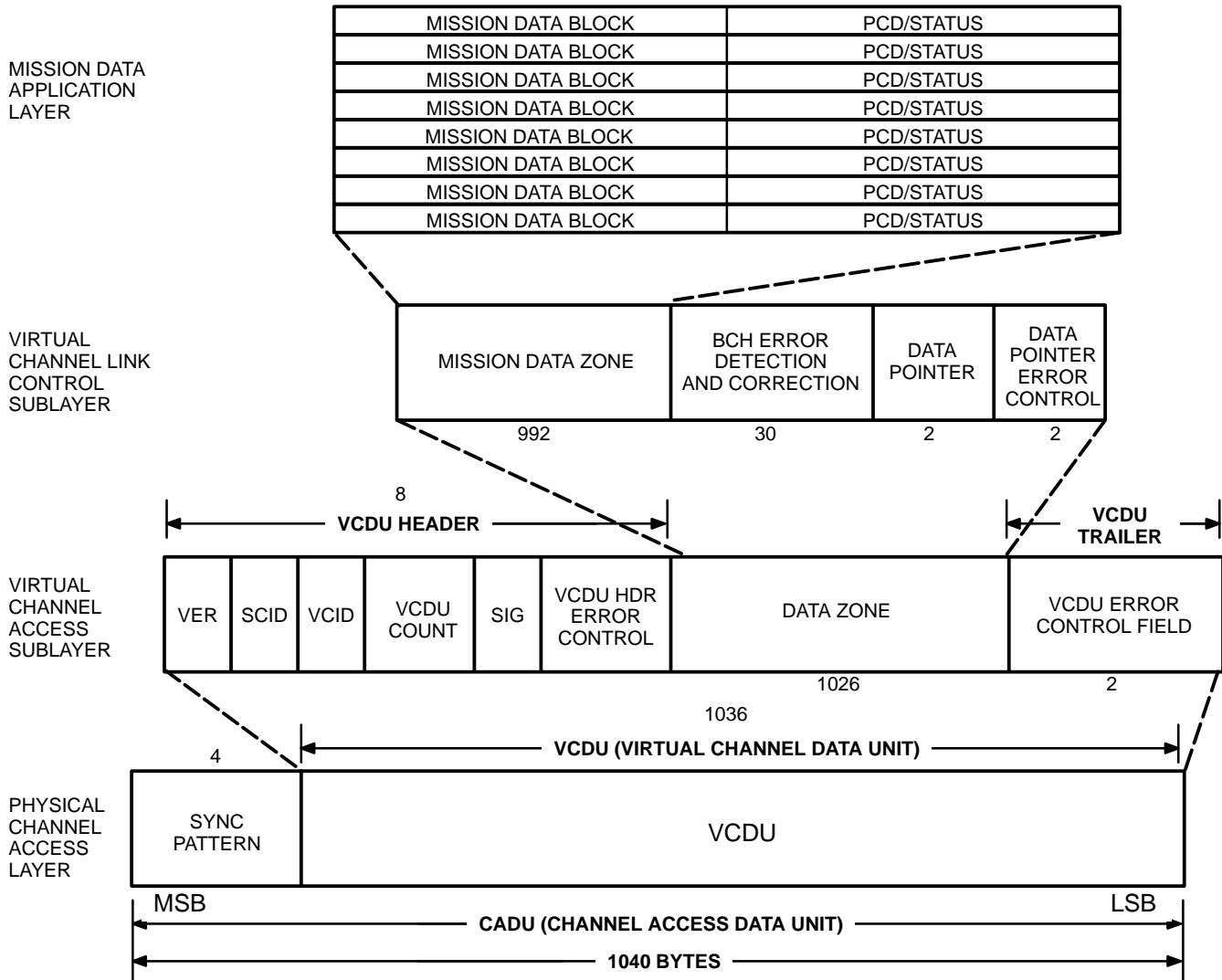

Figure 2. L7 Wideband Protocol Layers

For each of the data fields addressed in this Section 3, the following conventions are used:

1. The most significant bit is transmitted first.
2. The most significant bit in a data field is labeled bit 0.
3. The size of a data word is 8 bits.

3.1.1 MISSION DATA LAYER

The application layer consists of the mission data streams for the ETM+ payload. The data streams consist of 992 bit blocks of payload data. Detailed information on the formats of the mission data is provided in sections 3.2 and 3.3 of this volume.

3.1.2 VIRTUAL CHANNEL LAYER

The virtual channel layer functional responsibilities can be divided into three categories: bitstream segmentation with error detection and correction; providing headers and trailers as needed for

end-to-end flow control; providing synchronization for transfer across the Physical Channel. These functions are provided by the Virtual Channel Link Control sublayer (VCLC) and the Virtual Channel Access (VCA) sublayer, and the Physical Channel Access (PCA) sublayer, respectively. The most significant bit is transmitted first.

3.1.2.1 Virtual Channel Link Control Sublayer

The VCLC is responsible for segmenting the bitstream ETM+ data into a predefined zone of 7936 bits. The VCLC is responsible for providing error protection of the data zone. This will be accomplished by a 240 bit field containing a BCH EDAC field, and appended to the end of the mission data. A data pointer, defined below, is attached immediately following the mission data BCH code. The pointer is protected by a 16 bit field containing a BCH EDAC field as defined in section 3.1.2.1.1.1. The data pointer error control EDAC field is inserted following the data pointer, as shown in Figure 3.

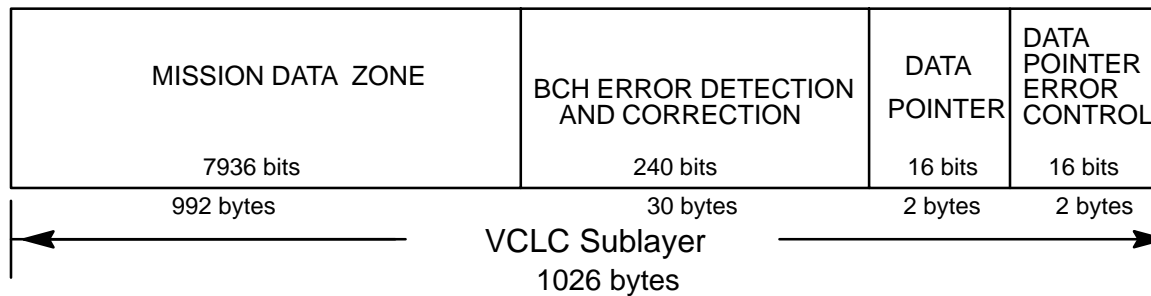

Figure 3. VCLC Sublayer

3.1.2.1.1 Data Pointer

The data pointer structure is as shown below in Figure 4. The data pointer field contains a synchronization pointer which correlates the transfer frame timing to the Minor Frame timing of the ETM+ data. The length of the pointer field is 16 bits. The 10 least significant bits are used to indicate the number of data words between the start of the data zone and the first word of the first full minor frame of the VCDU data zone. However, because this number turns out to be between 0 and 84, bits 6, 7, and 8 will be zero. The 6 most significant bits are each hardcoded to "0". The most significant bit is transmitted first. The data pointer is always valid except for the situation described in Section 3.2.6.

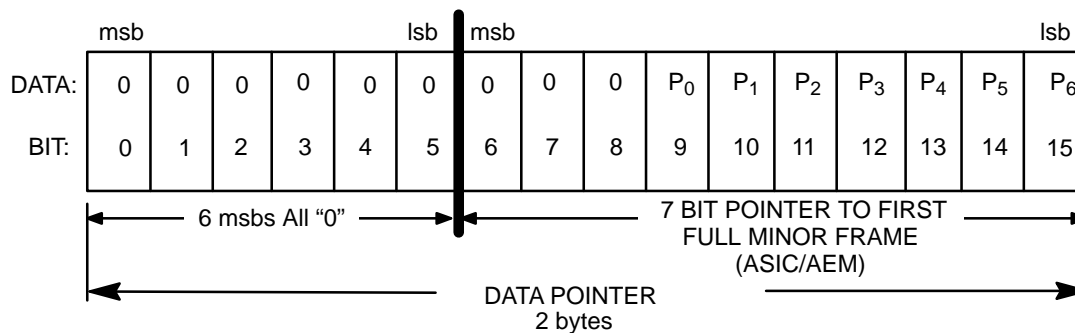

Figure 4. Data Pointer Bit Field Definition

3.1.2.1.2 Data Pointer Error Control

The Data Pointer field must have a separate error protection scheme than the mission data zone. The error protection will be accomplished using a (31,16,3) BCH code, which provides the capability to correct three (3) errors in 16 data bits and 15 code bits. This code is generated using the polynomial:

$$g(x) = x^{15} + x^{11} + x^{10} + x^9 + x^8 + x^7 + x^5 + x^3 + x^2 + x + 1$$

The code bits will be located in the 15 least significant bits of a two byte field immediately following the Data Pointer. In order to preserve the CCSDS eight bit field length requirement, a fill bit will be inserted at the beginning of the 15 code bits as shown in Figure 5. The value of the fill bit will be set to "0" at all times. Since the fill bit is "0", the BCH generator will not be affected.

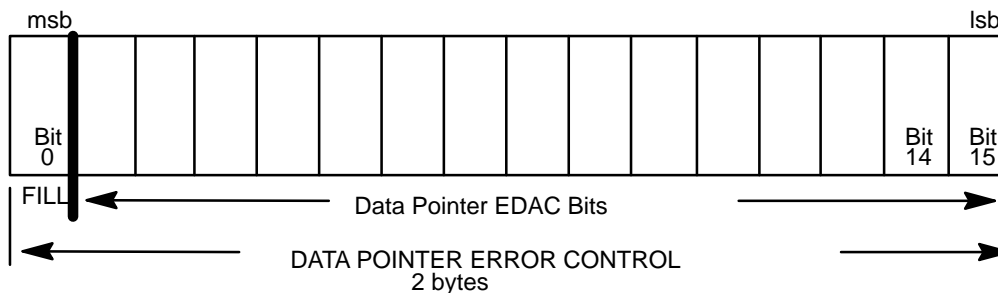

Figure 5. Data Pointer Error Control Bit Field Definition

3.1.2.1.3 Mission Data Zone

The Mission Data Zone is a 7936 bit (992 bytes) field that contains image or DC restore/calibration data of the ETM+.

3.1.2.1.3.1 Mission Data BCH Error Control

The mission data will be protected with a (1023, 993, 3) BCH code. The generator polynomial for this code:

$$g(x) = x^{30} + x^{28} + x^{23} + x^{21} + x^{19} + x^{16} + x^{12} + x^8 + x^4 + x + 1$$

This code has the capability to correct three errors in 993 data bits and 30 code bits. Since the mission data field consists of 8 blocks of 992 bits, a fill bit must precede each 992 bit block of mission data to correctly employ the BCH algorithm. The fill bit **will not** be transmitted. The value of the fill bit will always be "0". Proper error detection and correction by the ground processing software will require the insertion of a filler bit at the beginning of each 992 bit block prior to execution of the BCH code or will require preloading the intermediate result of the BCH code that is calculated from applying the preceding fill bit to the BCH algorithm.

BCH algorithm will generate 30 code bits for each of the eight 992 bit blocks of mission data. The 8 sets of 30 code bits will be appended to the end of the mission data field in a predefined 240 bit field. The first 8 bits will be the code bits corresponding to the first code bit in each of the 8 BCH encoders. Bits 8–15 will correspond to the second code bit in each of the 8 BCH encoders in the mission data zone, and so forth with the final 8 bits corresponding to the 30th, and final, check bit for each of the 8 BCH blocks. Figure 6 illustrates this relationship. Figure 7 illustrates the BCH encoding circuit. It should be noted that the the data transferred out of the encoder is not interleaved, however, the code bits are interleaved.

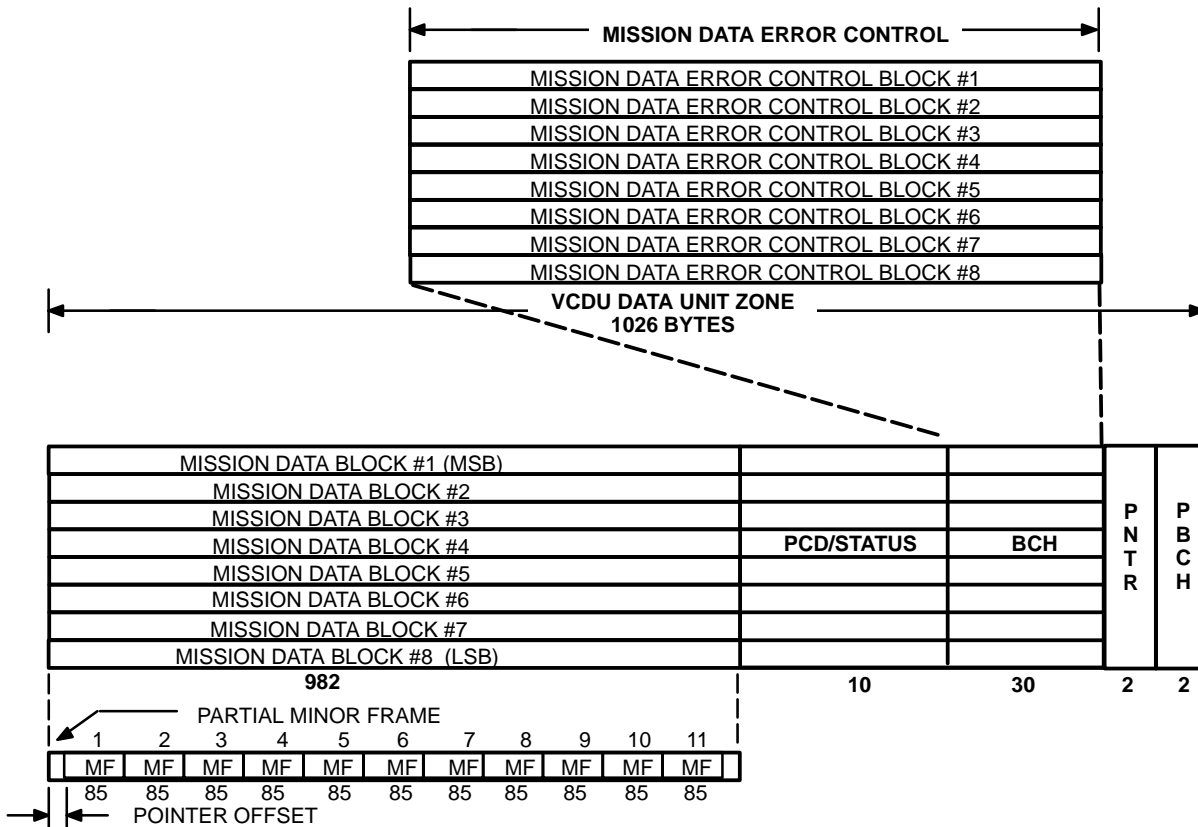

Figure 6. Mission Data Error Control BCH Code Block Relationships

3.1.2.2 Virtual Channel Access Sublayer

The VCA sublayer is responsible for appending the appropriate headers and trailers to the data stream to provide for end-to-end flow control. This is accomplished by inserting the 64 bit (eight byte) VCDU primary header at the start of the data stream, and appending the 16 bit (2 byte) VCDU Error Control Field at the end of the data stream.

3.1.2.2.1 VCDU Primary Header

The VCDU Primary header will contain 64 bits (eight bytes) due to the fact that the optional Header Error Control field has been included. The remaining fields are defined below and illustrated in Figure 8.

3.1.2.2.1.1 Version Number

The first two bits of the Primary header are reserved for the Version number of the CCSDS packet. The two Version bits will be set to 01₂, indicating a Version-2 CCSDS Packet.

3.1.2.2.1.2 Spacecraft Identifier

Bits 2 (two) through 9 (nine) are reserved for the Spacecraft Identifier. The Spacecraft ID is chosen by the Secretariat of the CCSDS. The value that has been assigned for Landsat 7 is 00010101₂.

3.1.2.2.1.3 Virtual Channel Identifier

Bits 10 through 15 of the Primary header are reserved for the Virtual Channel Identifier (VCID). The VCID field allows up to 64 virtual channels to run concurrently on one physical channel. For Landsat 7,

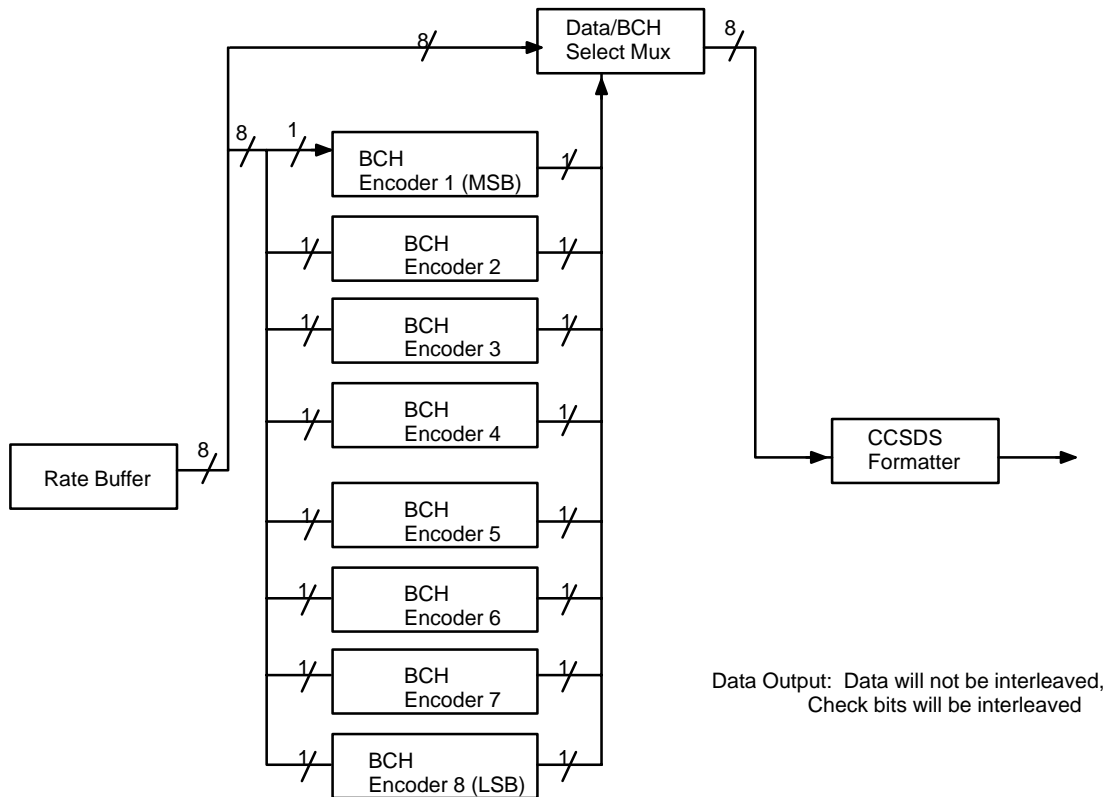

Figure 7. BCH Encoding

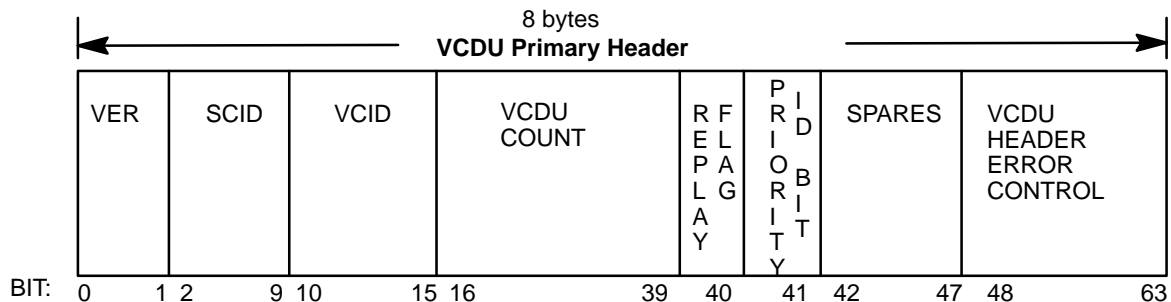

Figure 8. VCDU Primary Header

the VICID field will be used to identify from which channel the subject data was generated. For Landsat 7, Channel 1 identifies Format 1 data: Bands 1 through 5, and IR Band 6. Channel 2 identifies Format 2 data: IR Bands 6 and 7, and the Pan Band. The values will be as follows:

1. ETM+ Data Format 1 – 000001₂
2. ETM+ Data Format 2 – 000010₂

3.1.2.2.1.4 Virtual Channel Data Unit Counter

Bits 16 through 39 are reserved for the VCDU Counter field. The 24 bit field will be used in conjunction with the VICID to maintain a separate counter for each instrument channel. The first count will be zero and the counter will be reset to zero each time an instrument transitions from “standby” to “on” (ETM+). The counter will increment once for each VCDU. The counter will roll over when it

exceeds 16,777,215, irregardless of whether this occurs on scene boundaries or in the middle of a current scene.

3.1.2.2.1.5 Replay Flag

Bit 40 of the VCDU Primary header is reserved for the Replay Flag Bit. The Replay Flag will not be used in Landsat 7; therefore the value of this bit will be set to “0” for all VCDU’s.

3.1.2.2.1.6 Priority Identification Bit

Bit 41 of the VCDU header will be the Priority Identification Bit. This implementation is unique to Landsat 7. The Priority ID bit will be used to differentiate mission data that the system identifies as requiring immediate attention by ground processing. The implementation of this bit will be as follows:

1. Priority Data – 1_2
2. Routine Data – 0_2

3.1.2.2.1.7 Reserved Spares Field

Bits 42 through 47 are reserved for future applications by CCSDS. They will be set to the value of all zeros as follows:

1. Reserved Spares – 000000_2

3.1.2.2.1.8 VCDU Header Error Control Field

The optional EDAC to protect the header will be utilized for Landsat 7. Bits 48 through 63 will be the check symbols of a shortened Reed-Solomon (10,6) code and further described in Appendix B. The code protects all fields within the header with the exception of the VCDU counter. Consequently, the value of the VCDU header check symbols are known for a given instrument channel and data priority; (i.e., they do not need to be computed dynamically on the S/C but will be computed on the ground and checked for errors). The values for these fields will be defined as follows:

1. ETM+ Data Format 1 Priority – 6594_{16}
2. ETM+ Data Format 1 Routine – $BF82_{16}$
3. ETM+ Data Format 2 Priority – $03A5_{16}$
4. ETM+ Data Format 2 Routine – $D9B3_{16}$

3.1.2.2.2 VCDU Trailer

The VCDU Trailer is generally an optional component of the VCDU. However, CCSDS mandates that the VCDU Error Control Field be present within any channels that are not Reed-Solomon encoded. The Operational Control Field option will not be used.

3.1.2.2.2.1 VCDU Trailer Error Control Field

The VCDU Trailer Error Control Field is a 16-bit CRC code which provides the capability to detect errors that may have been introduced during data transmission. The last 16 bits of the VCDU, specifically, bits 8272 through 8287, will contain the 16 generated parity symbols. The generator polynomial is:

$$g(x)=x^{16} + x^{12} + x^5 + 1.$$

Both the encoder and decoder are initialized to the “all ones” state for each VCDU. The parity generation is performed over the entire data space of the VCDU, excluding the 16 bits of error control. The generated parity symbols are inserted into the VCDU error control field, which occupies the last 16 bits of the VCDU.

3.1.2.3 Physical Channel Access Sublayer

The Physical Channel Access Sublayer is responsible for generating a continuous and contiguous stream of serial data. The resulting data unit is known as a Channel Access Data Unit (CADU). The Landsat 7 Wideband CADU is shown in Figure 9.

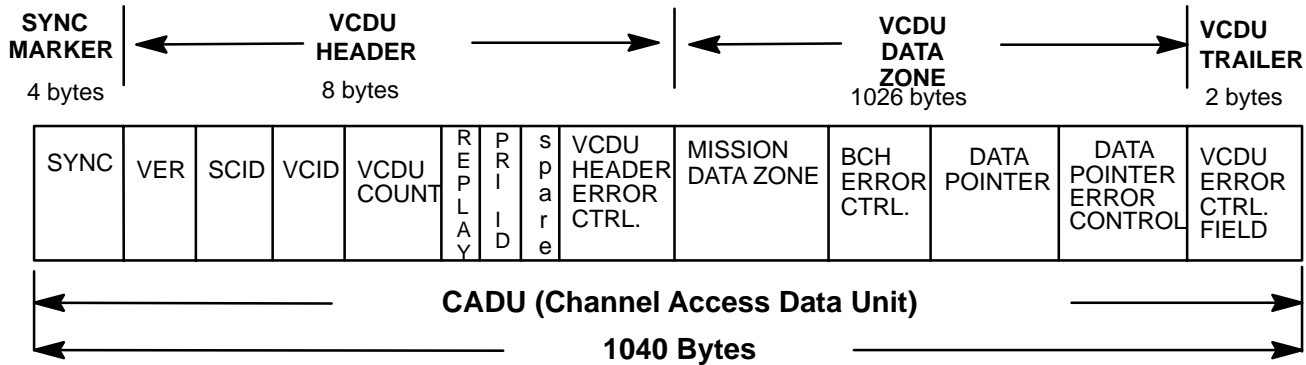

Figure 9. Channel Access Data Unit Description

3.1.2.3.1 Pseudo-Randomizer

The use of the pseudo-randomizer is necessary to guarantee the bit transition density required to maintain bit synchronization with the received signal. The method for ensuring sufficient transitions is to exclusive-OR each bit of the VCDU (does not include the Sync field) with a standard pseudo-random sequence. On the receiving end, the same sequence is exclusive-ORed with the received VCDU to remove the randomized pattern and restore the original data. The generator polynomial, logic diagram, and associated usage constraints can be found in CCSDS 101.0–B–3, paragraphs 6.3, 6.4 and 6.5.

3.1.2.3.2 Synchronization Marker

A CADU is delineated by a synchronization marker. CCSDS defines this synchronization marker to be a 32 bit field located at the beginning of each CADU. The most significant bit is transmitted first. The synchronization marker will have the following value:

1. CADU Synchronization Marker – (msb) **1ACFFC1D**₁₆ (lsb)

3.1.3 PHYSICAL CHANNEL LAYER

The Physical Channel layer provides the medium for transmission of the CADU’s between the space vehicle and the ground. Details regarding the data modulation formats can be found in the RF ICD Between Landsat 7 and the Space Network (SN), Ground Network (GN), and Landsat 7 Ground Station (LGS), 23007638.

3.2 ETM+ MISSION DATA FORMATS

The Enhanced Thematic Mapper Plus (ETM+) is a payload on the Landsat 7 space vehicle. The ETM+ payload contains sensors that detect earth scene radiation in visible and near infrared (VNIR) bands,

short wavelength infrared (SWIR) bands, and thermal long wavelength infrared (LWIR) band. ETM+ image data are stuffed into most of the 7936 bit slots in CADU's as defined in Section 3.1 of this volume. The structure of the ETM+ data formats within a given scene for all data modes are the subject of this section.

3.2.1 ETM+ DATA FLOW AND FORMATTING

Each of the two multiplexers receives all 136 analog inputs (one per detector) from focal planes. These inputs are separated into two groups; 88 inputs containing Bands 1-6 and 56 inputs containing Bands 6, 7, and Pan. The format of the focal planes, Instantaneous Field of View (IFOV), position and orientation of the detectors are described in Section 3.2.2. Each of the multiplexers has two high speed outputs that simultaneously output both scene data formats such that one activated multiplexer provides for the required ETM+ output data while the other multiplexer remains in an unpowered standby mode as selected by external command. Multiplexer outputs will be combined as shown in Figure 10 to provide two high speed data outputs. The A/D converter output within each multiplexer provides digital data that is transferred to the Minor Frame Formatters. The Minor Frame formatters format all of the data into the two scene data formats described in Section 3.2.5.3 which have the minor frame structure described in Section 3.2.4. After construction of the minor frames, the PCD/Status words are added (Section 3.2.6), the data is BCH encoded, and CCSDS formatted. The PCD data types and formats are described in Section 3.2.7. The description of the BCH encoding and CCSDS formatting are provided in Section 3.1. Figure 10 provides a functional diagram of the data flow and formatting.

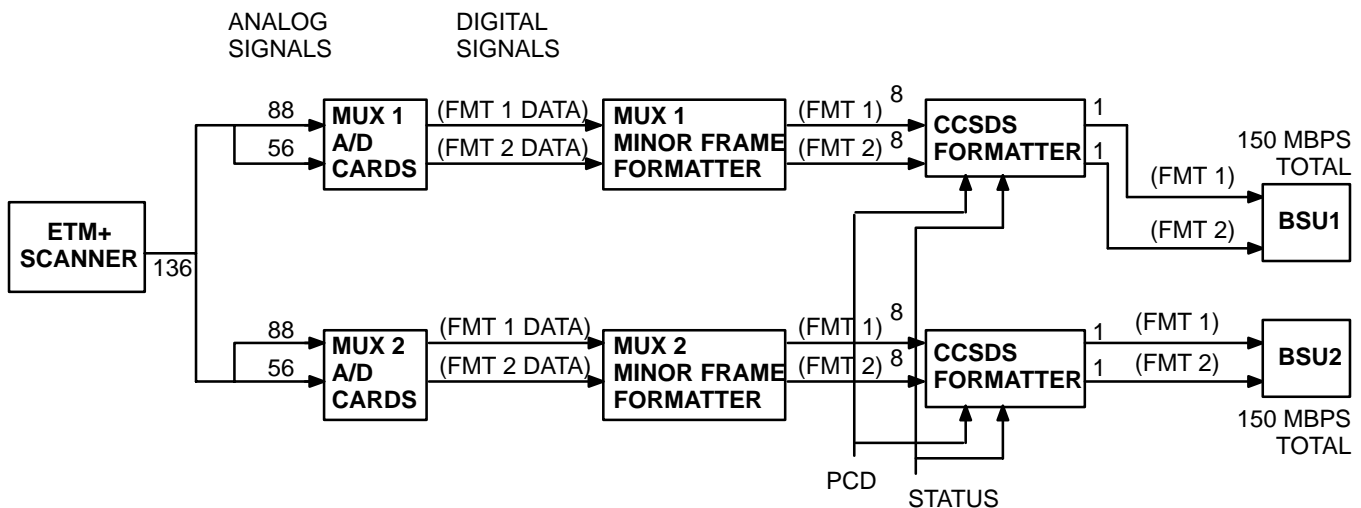

Figure 10. ETM+ Data Flow and Formatting

3.2.2 FOCAL PLANE, SPECTRAL BANDS, IFOV SIZE, AND GROUND RESOLUTION

ETM+ collects, filters, and detects radiation from the earth in a swath 185 km wide as it passes overhead and provides the necessary cross track scanning motion while the spacecraft orbital motion provides an along-track scan. The ETM+ scanner contains two focal plane assemblies. The primary focal plane assembly including optical filters, detectors, and preamplifiers for five of the eight ETM+ spectral bands (Bands 1-4, 8). The second focal plane assembly is the cold focal plane assembly. This includes optical filters, infrared detectors, and input stages for the remaining three ETM+ spectral bands (Bands 5, 6, and 7). When the ETM+ focal plane and scan pattern are projected on the ground (Figure 11), detector No. 1 of each band appears at the leading, Southern edge of the scan line. At each instance of time, the odd

detectors are to the East and the even detectors to the west and shifted North relative to the odd detectors by the distance of one (1) detector (pixel) length in that band.

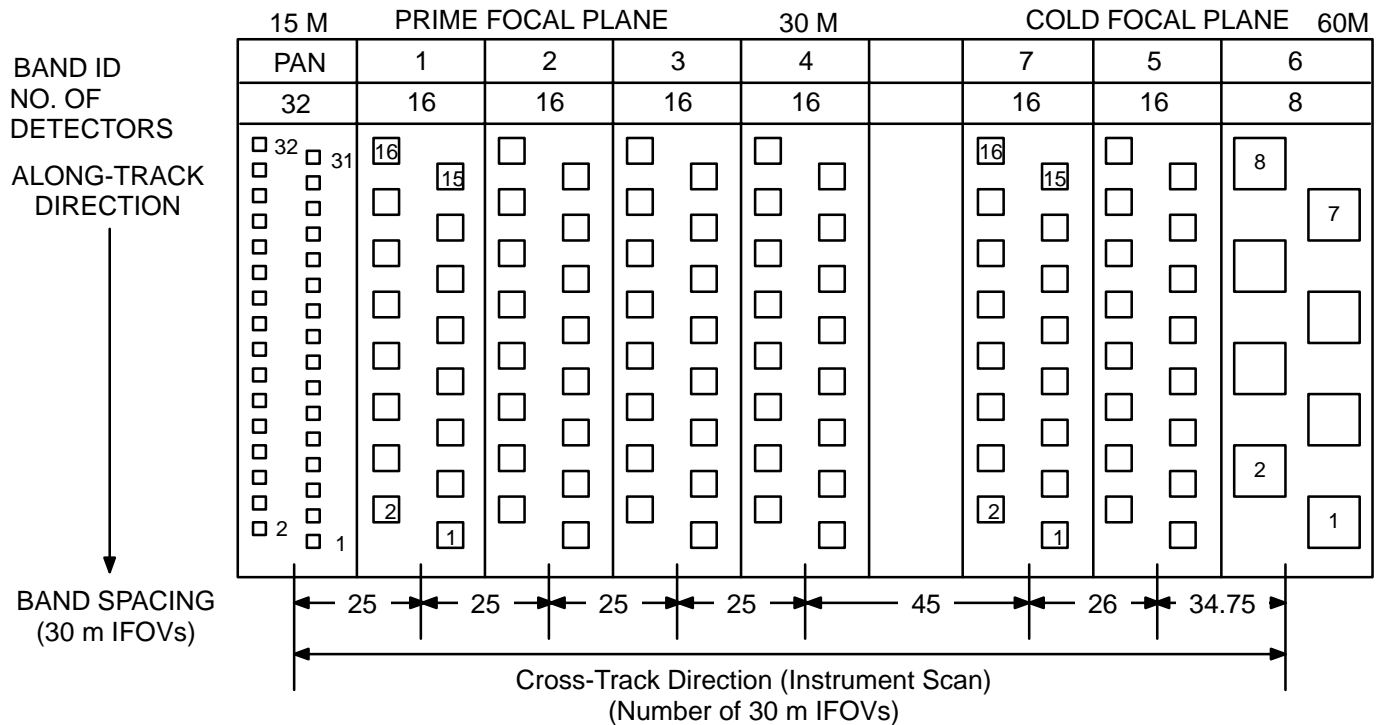

Figure 11. Focal Plane Layouts Projected Onto Earth Surface

3.2.3 ETM+ MAJOR FRAME STRUCTURE

The ETM+ data stream is composed of a continuous succession of Major Frames. For nominal operations on orbit and in vacuum each Major Frame contains the data for an entire period of one complete scan of the ETM+ scan mirror (either direction). A Major Frame period ~ 71.820 ms includes not only the period during a scan but also the turnaround interval (including calibration data) when the scan mirror changes direction for the next scan. ETM+ Major frames are partitioned into Minor Frames (~ 7473 Minor Frames per Major Frame). During both Instrument and Observatory level I&T, most testing will be conducted at ambient temperature and pressure, which increases the turnaround interval so that the Major Frame period becomes 71.993 ms with ~ 7491 Minor Frames per Major Frame. It should be noted : (a) these numbers are nominal, and, (b) turn-around-time will begin to increase after a couple of years if wear occurs on-orbit as happened with Landsat 5. Turn-around-time can be trended with the wideband data by using the time code data (section 3.2.5.2) and the active scan time (section 3.2.5.5). The first Minor Frame of the Major Frame is initiated by a mechanically/optically timed pulse. This Minor Frame is called the Line Sync Code or Scan Line Start (SLS). The six Minor Frames immediately following the SLS Minor Frame describe the spacecraft time (Time Code). Scene Data (partitioned into Minor Frames) occupies the Major Frame until another mechanically/optically timed mirror pulse preempts the scene data with an End-of-Line (EOL) Code. This code signals the end of an active image scan. Shortly following the EOL code, the Scan Line Length (SLL) and Scan Direction (SD) codes occur (Summarized as Scan Line Data in Section 3.2.5.5). The data provided in both the Scan Line Length and the Scan Direction codes are descriptions of the scan prior to the current scan. Figure 12 describes the relationship between major frames, minor frames, and VCDUs.

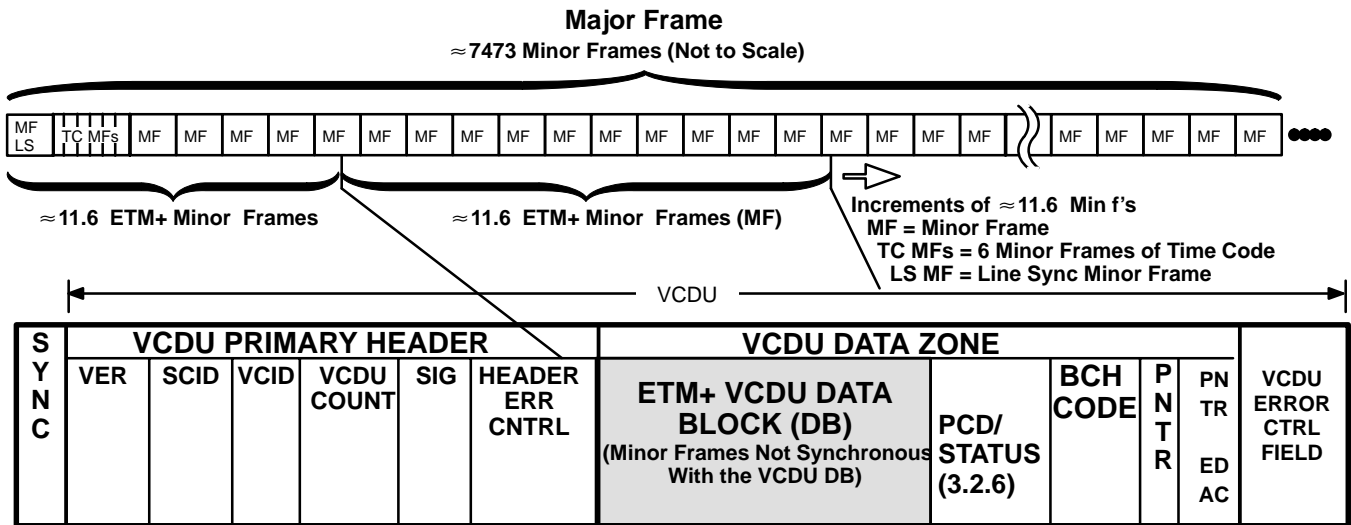

Figure 12. ETM+ Major Frame, Minor Frames, CADU

3.2.4 MINOR FRAME DATA STRUCTURE

The Minor Frame Data Structure is a specific pattern for organizing groups of ETM+ data words. This pattern is based on the architecture of the L-7 Auxiliary Electronics Module (AEM) hardware that samples, digitizes, and groups analog video signals from the ETM+ scanner to form scene data. The Minor Frame Data structure is 85 words (8 bits) in length consisting of 16 separate groups of 5 words, 4 data words from Band 6, and 1 spare data word. Band 6 data shall alternate between the odd and even pixels for each successive minor frame and shall be resynchronized to odd pixel data for the first minor frame (line sync code) of each new scan. Each bit of the spare data word is set to zero. The Minor Frame Data structure is shown in Figure 13. Note that the odd numbered words are transmitted first followed by the even numbered words and then Band 6 data. Format 1 contains Band 6 low gain and Format 2 Band 6 high gain when commanded to the appropriate gain setting to acquire Band 6 data (BP6 = Lo Gain, BR6 = Hi Gain).

3.2.5 MINOR FRAME FORMATS

Seven separate minor frame formats or minor frame format groups are used to accommodate the required ETM+ scan events and scene data. The minor frame formats and data content are described in the following paragraphs. Note that the tables describing the formats are shown in numeric word sequence and not in time sequence.

3.2.5.1 Line Sync Code Format (Scan Line Start)

The L-7 AEM asynchronously detects the occurrence of the trailing edge line start pulse from the scan mirror assembly. Upon detection of the start pulse, a new scan line is initiated which is synchronized to the start of the next data word. The Line Sync Code is generated by the L-7 AEM at the beginning of each new scan line and inserted into minor frame zero and pre-empts all minor frame video except Band 6 data. However, Band 6 data is not valid for minor frame zero. In addition, each of the 16 groups of 5 words within a given minor frame will contain a single bit binary value (0 or 1) that is replicated for all of the bits in the group (40 bits per group). Table 1 lists the single bit values for the Line Sync Code.

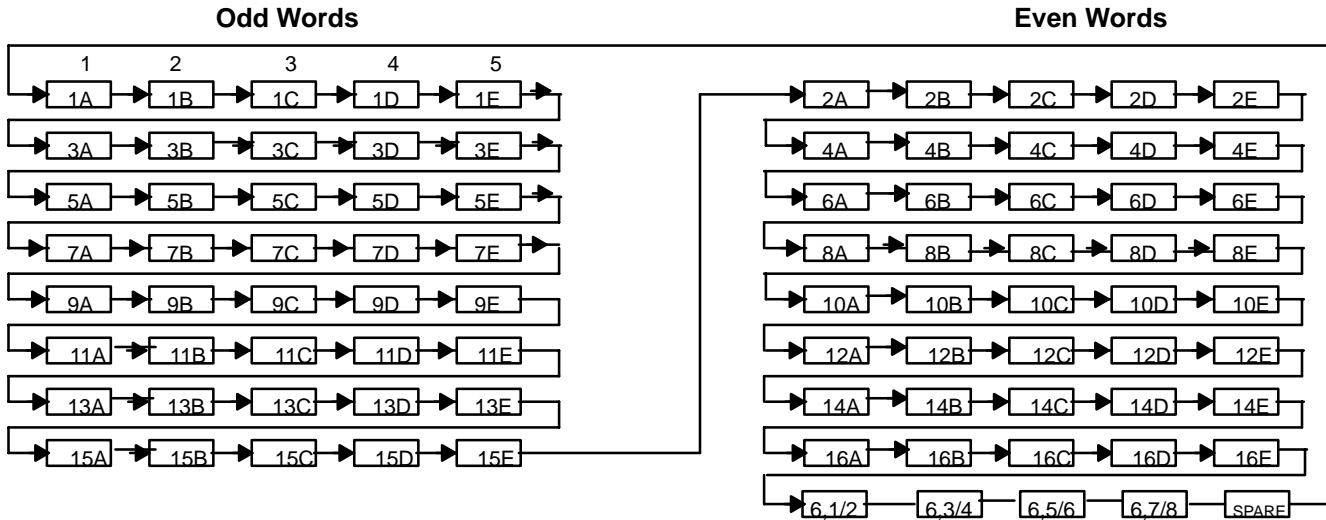

Mf 0, 2, 4 . . . – odd data words
Mf 1, 3, 5 . . . – even data words

Representation: 16 Groups of 5 Words Plus 1 Group for Band 6 Plus Spare Word

Figure 13. Minor Frame Data Structure

TABLE 1. LINE SYNC CODE (LSC) FORMAT (1 MINOR FRAME)

1A-E	2A-E	3A-E	4A-E	5A-E	6A-E	7A-E	8A-E	9A-E	10A-E	11A-E	12A-E	13A-E	14A-E	15A-E	16A-E
"1"	"0"	"1"	"0"	"1"	"0"	"1"	"0"	"1"	"0"	"1"	"0"	"1"	"0"	"1"	"0"

3.2.5.2 Time Code Data Format

The time code data is collected from the spacecraft for transmission starting at the minor frame boundary immediately following each Line Sync Code. The time code data is received from the spacecraft and inserted into six (6) contiguous minor frames. Each of the 16 groups of 5 data words within a given minor frame will contain a single bit binary value (0 or 1) of information that is replicated for all of the bits in the group (40 bits per group). Table 2 presents the position of each information bit for the six minor frames. The Time Code data is 480 data words and conforms to the Minor Frame structure as shown in Figure 13, and pre-empts all minor frame video except Band 6 data. The Time Code information is encoded in "8421" (natural) Binary-Coded Decimal (BCD) except for 0.0625 msec which is binary. Transmission order is left to right, top to bottom, odd numbered groups first, then even numbered groups last.

TABLE 2. TIME CODE DATA FORMAT (6 MINOR FRAMES)

MF#	1A-E	2A-E	3A-E	4A-E	5A-E	6A-E	7A-E	8A-E	9A-E	10A-E	11A-E	12A-E	13A-E	14A-E	15A-E	16A-E
1	0	1	0	1	0	1	0	1	0	1	0	1	0	1	0	1
2	0	0	10 Days (8)	1 Day (8)	0	1 Hr (8)	0	1 Min (8)	0	1 Sec (8)	100 msec (8)	10 msec (8)	1 msec (8)	1/16 msec (8)	SCID #1 (MSB) '0'	1
3	0	0	10 Days (4)	1 Day (4)	0	1 Hr (4)	10 Min (4)	1 Min (4)	10 Sec (4)	1 Sec (4)	100 msec (4)	10 msec (4)	1 msec (4)	1/16 msec (4)	SCID #2 '1'	1
4	0	100 Days (2)	10 Days (2)	1 Day (2)	10 Hrs (2)	1 Hr (2)	10 Min (2)	1 Min (2)	10 Sec (2)	1 Sec (2)	100 msec (2)	10 msec (2)	1 msec (2)	1/16 msec (2)	SCID #3 '1'	1
5	0	100 Days (1)	10 Days (1)	1 Day (1)	10 Hrs (1)	1 Hr (1)	10 Min (1)	1 Min (1)	10 Sec (1)	1 Sec (1)	100 msec (1)	10 msec (1)	1 msec (1)	1 msec (1)	SCID #4 (LSB) '1'	1
6	0	0	0	0	0	0	0	0	0	0	0	0	0	0	0	0

(n) = BCD Weight (8, 4, 2, or 1) except column 15A-E (natural binary)
msec = milliseconds
[n] = Binary coded fraction weight

3.2.5.3 Scene Data Formats

Scene data is provided in two specified Scene Data formats (Scene Data Format 1 and Scene Data Format 2). Scene data transmission starts at the minor frame boundary immediately following the Time Code and conforms to the Minor Frame Data Structure. Transmission of scene data continues until the start of the next End of Line Pattern code. For reference, 6313 Minor Frames of scene data are nominally transmitted during any given scan cycle. The digitized scene data from the analog video inputs can be organized into either of two minor frame scene data formats. A given multiplexer is capable of simultaneously providing both formats and has two high rate serial digital outputs that are each allocated to providing one of the two formats. Table 3 lists the spectral bands allocated to each of the two formats. Figure 14 presents the scene data pixel pattern for Scene Data Format 1 which includes bands 1 through 6. Figure 15 presents the specific scene data pixel pattern for Scene Data Format 2 which includes bands 6, 7, and PAN.

TABLE 3. SCENE DATA FORMATS

BAND	INPUT	SAMPLE RATE	GROUND FOV	FORMAT 1	FORMAT 2
1	16	104 kHz	30 meters	x	
2	16	104 kHz	30 meters	x	
3	16	104 kHz	30 meters	x	
4	16	104 kHz	30 meters	x	
5	16	104 kHz	30 meters	x	
6	8	52 kHz	60 meters	x	x
7	16	104 kHz	30 meters		x
PAN	32	208 kHz	15 meters		x

3.2.5.4 End of Line Pattern Code Format

The occurrence of the line stop pulse generated by the ETM+ scan mirror assembly is asynchronously detected by the L-7 AEM. Upon detection of the line stop pulse, an End of Line Pattern Code is generated and is synchronized to the Minor Frame boundary of the next minor frame. The End of Line Pattern code conforms to the Minor Frame Data Structure and preempts all minor frame video except Band 6 data. The length of the End of Line Pattern Code included in 2 consecutive minor frames is 160 bytes. The End of Line Pattern Code will be inserted into two contiguous minor frames. Each of the 16 groups of 5 data words within the minor frame will contain a single bit binary value (0 or 1) that is replicated for all of the bits in the group (40 bits per group). Table 4 lists the single bit values to be used. The values listed in Table 4 are used for both Minor Frames.

TABLE 4. END OF LINE PATTERN CODE (1 OF 2 MINOR FRAMES)

1A-E	2A-E	3A-E	4A-E	5A-E	6A-E	7A-E	8A-E	9A-E	10A-E	11A-E	12A-E	13A-E	14A-E	15A-E	16A-E
"0"	"0"	"0"	"0"	"0"	"0"	"0"	"0"	"1"	"1"	"1"	"1"	"1"	"1"	"1"	"1"

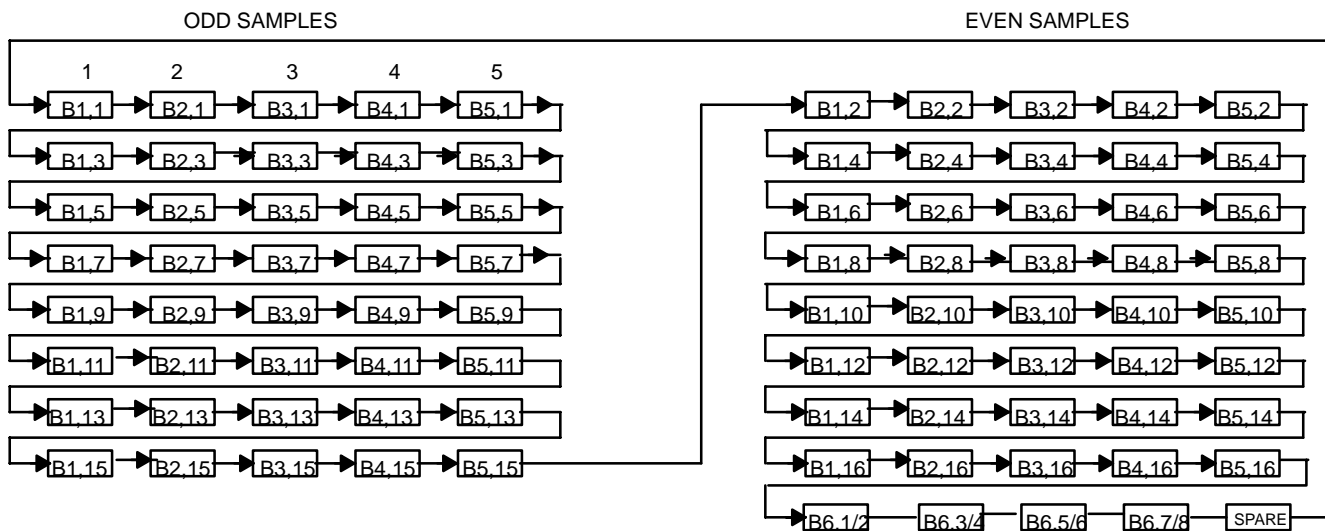

Representation: BX,Y = Band X, Detector Y; Band 6 = Primary

Figure 14. Scene Data Format 1

3.2.5.5 Scan Line Length/Direction Data

The Scan Mirror Assembly (SMA) may be operated in either of two modes: (a) the primary mode, referred to as the Scan Angle Monitor (SAM) Mode, and (b) the back-up, or Bumper Mode. The primary SAM mode uses feedback from three split optical SAM sensors (at both ends and the middle of the mirror travel) to correct the motion of the scan mirror to keep the first half and second half scans as identical as possible, by applying two torque pulses during each turn-around (the timing constants of the pulses being adjusted based on the behavior of the scan mirror during the previous forward and reverse scan). In contrast, the back-up Bumper mode also applies two torque pulses during the turn-arounds,

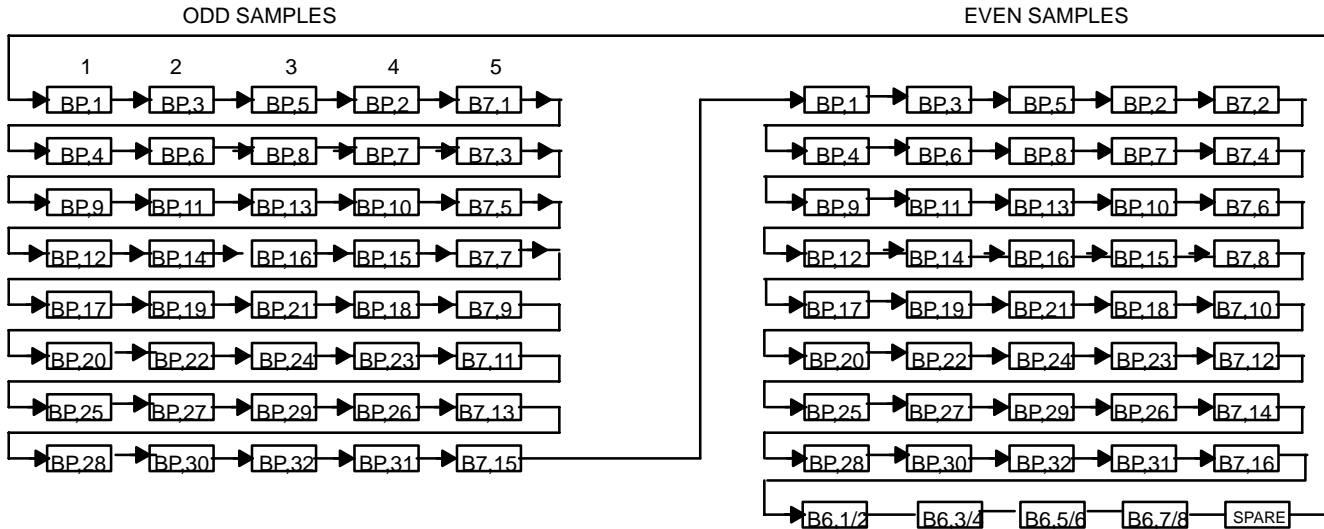

Representation: BX,Y = Band X, Detector Y; Band 6 = Redundant

Figure 15. Scene Data Format 2

but their time constants are fixed (chosen so that the SAM and Bumper operational characteristics shall be as similar as practical) and simulated SAM pulses are issued to maintain synchronization of the ETM+ shutter, scan line corrector, the SMA processor and the wide band data.

In each mode, scan line length/direction data is collected from the SMA for transmission starting at the Minor Frame boundary immediately following each End of Line Code. The scan line length/direction data conforms to the minor frame data structure and preempts all minor frame video data except band 6 data. The length of the scan line data is 160 data words (2 minor frames). Scan line data is received from the SMA with the ETM+ scanner and inserted into two (2) contiguous minor frames. Each of the 16 groups of 5 data words within a given minor frame will contain a single bit binary value (0 or 1) of information that is replicated for all bits in the group (40 bits per group). All scan line information corresponds to the scan prior to the current scan.

The position of each information bit for two minor frames is described in Table 5A for the primary, SAM mode and it Table 5B for the back-up, Bumper mode. In the SAM mode, the scan length information is given in two (2) twelve (12) group fields and the scan direction in an eight (8) group field. In the telemetry stream, the three (3) fields are interleaved as shown in Table 5A; together, they total 32 groups of 5 data words and comprise the two minor frames of scan line length/direction data. The first field of data "SHSERR" is the second half scan error (in counts) from a nominal 161,165. The second data field "FHSERR" is the first half scan error (in counts) from a nominal 161,164. Both scan error fields are comprised of a sign bit and 11 binary weighted bits, most significant bit first. Negative magnitudes (sign = 1) are two's complement. The active scan time (in seconds) can be computed using the following formula:

$$\text{Active Scan Time (T}_{\text{AST}}) = 2 \times \left\{ (161,164 - T_{\text{FHSERR}}) + (161,165 - T_{\text{SHSERR}}) \right\} \times \left[\left(\frac{120}{119} \right) \times \left(\frac{7}{74.914 \times 10^6} \right) \right]$$

The third data field gives the direction of the scan. A forward scan (West to East, descending node) is denoted by ones. A reverse scan is denoted by all zeros.

In the case of the Bumper mode, the two minor frames contain two interleaved fields, as shown in Table 5B. The first field of data, a twenty-four (24) group field, is the Bumper-to-Bumper (B-B) time, which is the absolute transition time in counts from bumper to bumper. The most significant bit is again first. The nominal Bumper-to-Bumper time is 71.820 msec and can be computed (in seconds) as follows:

$$\text{Bumper-to-Bumper Time (T}_{\text{BTBT}}) = 2 \times T (\text{B-B counts}) \times \left[\left(\frac{120}{119} \right) \times \left(\frac{7}{74.914 \times 10^6} \right) \right]$$

The second data field in the Bumper mode is the same as the third field in the SAM mode and again gives the scan direction: A forward scan (West to East, descending node) is denoted by ones. A reverse scan is denoted by all zeros.

TABLE 5A. SAM MODE SCAN LINE DATA (2 MINOR FRAMES)

GROUPS OF 5 DATA WORDS																
MF#	1-AE	2A-E	3A-E	4A-E	5A-E	6A-E	7A-E	8A-E	9A-E	10A-E	11A-E	12A-E	13A-E	14A-E	15A-E	16A-E
1	SHS ERR Bit 1 (±)	SHS ERR Bit 9	SHS ERR Bit 2 (MSB)	SHS ERR Bit 10	SHS ERR Bit 3	SHS ERR Bit 11	SHS ERR Bit 4	SHS ERR Bit 12 (LSB)	SHS ERR Bit 5 (LSB)	FHS ERR Bit 1 (±)	SHS ERR Bit 6	FHS ERR Bit 2 (MSB)	SHS ERR Bit 7	FHS ERR Bit 3	SHS ERR Bit 8	FHS ERR Bit 4
2	FHS ERR Bit 5	SCN DIR	FHS ERR Bit 6	SCN Dir	FHS ERR Bit 7	SCN DIR	FHS ERR Bit 8	SCN DIR	FHS ERR Bit 9	SCN DIR	FHS ERR Bit 10	SCN DIR	FHS ERR Bit 11	SCN DIR	FHS ERR Bit 12 (LSB)	SCN DIR

SHS ERR: Second Half Scan Error (± counts from nominal value of 161,165 counts).
 FHS ERR: First Half Scan Error (± counts from nominal value of 161,164 counts).
 SCN DIR: Scan Direction ("0" = Reverse, "1" = Forward).

TABLE 5B. BUMPER MODE SCAN LINE DATA (2 MINOR FRAMES)

GROUPS OF 5 DATA WORDS																
MF#	1-AE	2A-E	3A-E	4A-E	5A-E	6A-E	7A-E	8A-E	9A-E	10A-E	11A-E	12A-E	13A-E	14A-E	15A-E	16A-E
1	B-B Time Bit 1 (MSB)	B-B Time Bit 9	B-B Time Bit 2	B-B Time Bit 10	B-B Time Bit 3	B-B Time Bit 11	B-B Time Bit 4	B-B Time Bit 12	B-B Time Bit 5	B-B Time Bit 13	B-B Time Bit 6	B-B Time Bit 14	B-B Time Bit 7	B-B Time Bit 15	B-B Time Bit 8	B-B Time Bit 16
2	B-B Time Bit 17	SCN DIR	B-B Time Bit 18	SCN DIR	B-B Time Bit 19	SCN DIR	B-B Time Bit 20	SCN DIR	B-B Time Bit 21	SCN DIR	B-B Time Bit 22	SCN DIR	B-B Time Bit 23	SCN DIR	B-B Time Bit 24 (LSB)	SCN DIR

B-B Time: Absolute transition time from bumper to bumper in counts.
 SCN DIR: Scan Direction ("0" = Reverse, "1" = Forward)

3.2.5.6 Calibration Data

3.2.5.6.1 Internal Calibration System

An internal calibration system is provided within the ETM+ instrument to assist in performing radiometric calibration of image data. This system consists of an obscuration shutter assembly which includes a set of calibration source lamps with associated optical conductors for bands 1 through 5, 7, and Panchromatic band. A temperature controlled blackbody surface is employed as a calibration source for the thermal band (Band 6).

The obscuration shutter also provides a dark surface for use in setting the DC reference level for Bands 1 through 5, 7, and Pan with the instrument electronics, and provides a second known temperature surface for use in the thermal band calibration.

Calibration and DC reference recognition is achieved at the completion of each imaging scan with the obscuration shutter rotating into view of the detectors. As the shutter passes through these optical paths, the calibration lamps, blackbody surface, and the dark surfaces pass through the detector's field of view. As a result, a calibration radiance signal and a DC restore level are provided between active scans for bands 1 through 5, 7, and Pan detectors. For the Band 6 detectors, temperature levels are provided between active scans. These data are intended for use in establishing system calibration criteria during image processing.

During each mirror turnaround period, the internal calibration system for Bands 1 through 5, 7, Band 6, and the Pan Band provides calibration data over approximately 143 minor frames (1374 μ sec) preceding the reverse scan and 153 minor frames (1470 μ sec) preceding the forward scan. Refer to Table 8 and Figures 16 and 17 for further details regarding nominal start and stop minor frame locations of the Line Sync Code, Time Code, End-of-Line (EOL), Scan Line Length and Scan Direction, Shutter Obscuration, the internal Calibration Period, DC Restore and Postamble Data. Note that the start and stop minor frame locations are approximate and may vary with Scan Mirror Assembly operating conditions and over time.

Two lamps are available to provide calibration stimuli for Bands 1 through 5, 7, and the Pan Band. The circuitry for each lamp drive is unique such that the calibration lamp circuitry and lamp are completely redundant. Each lamp has two states (On or Off). Calibration data format is just like that of scene data.

3.2.5.6.2 Multiplexer Bi-State Gains and A/D Conversion

Each spectral band may be uniquely commanded to either of two gain states (High or Low). In addition, each multiplexer has dual redundant circuitry for Band 6 and the gain for each circuit may be set independently. The high gain state increases the instrument's capability to detect subtle signal changes, while the low gain feature is intended for scenes of high reflectivity and greater scene dynamic range. This operational capability is intended to be used according to high or low radiance of geographic areas.

For reference, Table 6 presents the Band to A/D Converter assignment summary.

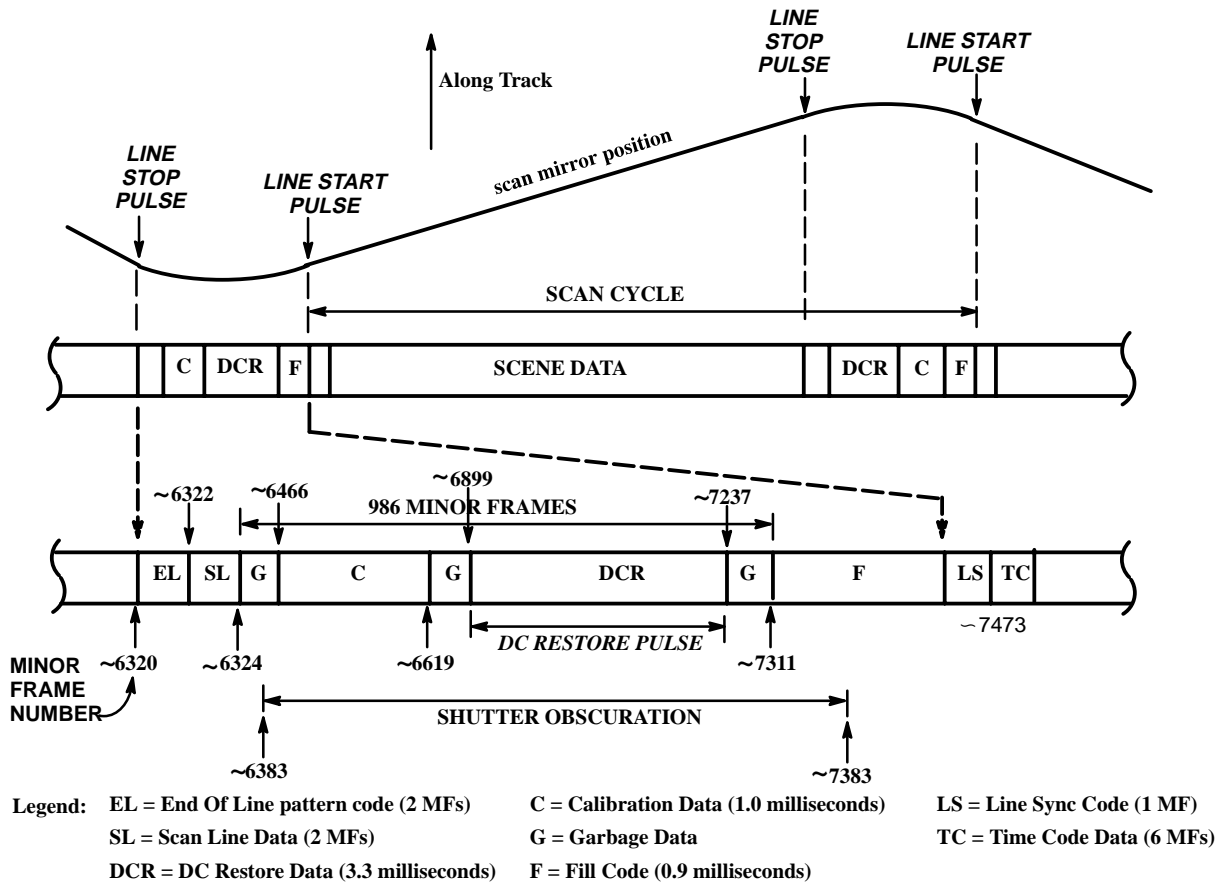

Figure 16. Major Frame Events (Reverse Scan)

TABLE 6. BAND TO A/D CONVERTER ASSIGNMENTS

ANALOG CHANNELS	BAND	A/D 1	A/D 2	A/D 3	A/D 4	A/D 5	A/D 6
Format 1							
	Band 1	X _A					
	Band 2		X _A				
	Band 3			X _A			
	Band 4				X _A		
	Band 5					X _A	
	Band 6 _P						X _B
Format 2							
	Pan	X _B	X _B	X _B	X _B		
	Band 6 _R					X _B	
	Band 7						X _A

Legend: P = Primary A = A side of card
R = Redundant B = B side of card

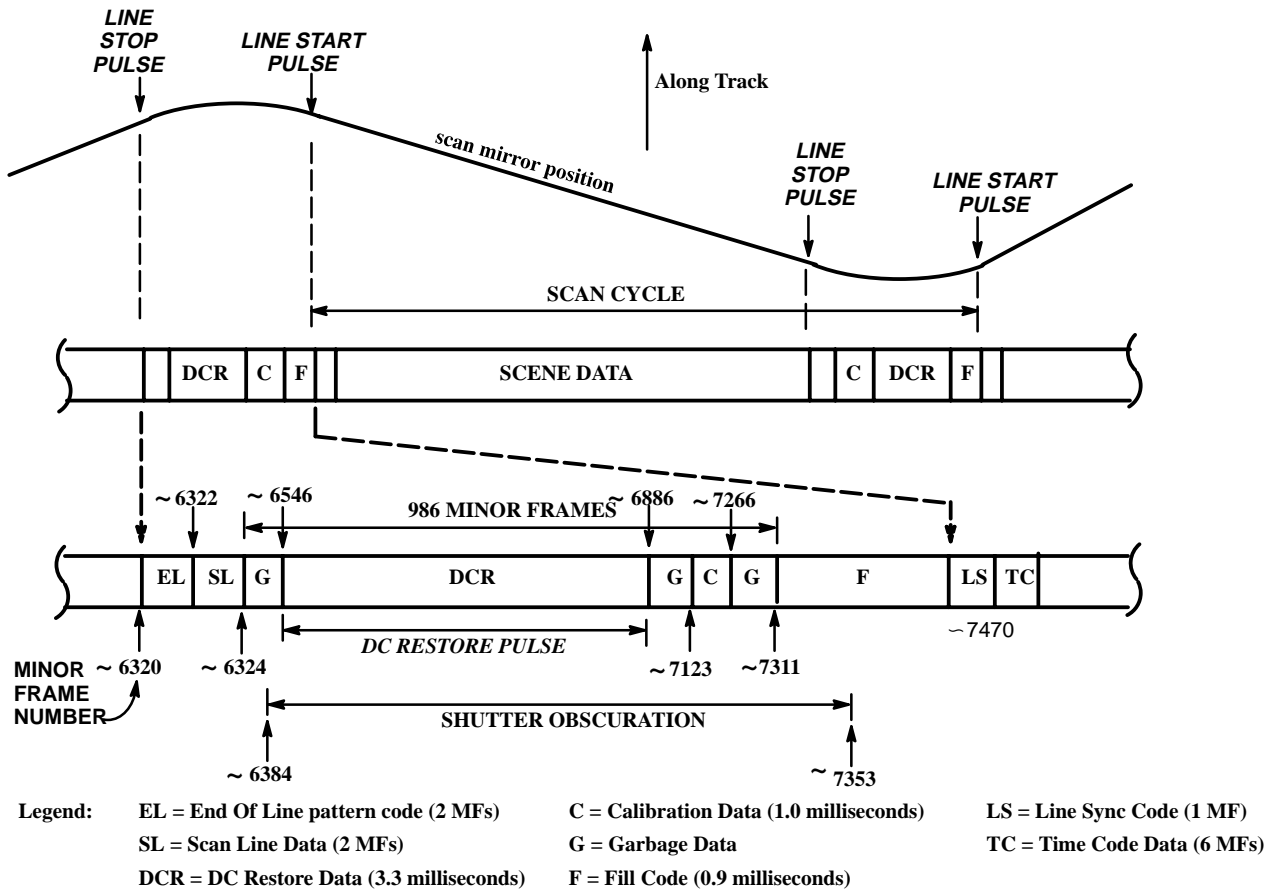

Figure 17. Major Frame Events (Forward Scan)

TABLE 7. DATA FORMAT

DATA STREAM EVENT	EVENT DESCRIPTION	FORWARD SCAN START MF	FORWARD SCAN STOP MF	REVERSE SCAN START MF	REVERSE SCAN STOP MF
Line Sync Code	MF Sync Code preempts all video stream data except Band 6, 5 '1's, 5 '0's (eight times)	0	0	0	0
Time Code	6 Ms of time code received from S/C preempts all video stream data except Band 6	1	6	1	6
End-of-line	Two MF's, 40 '0's, 40 '1's, 40 '0's, 40 '1's	~6320 ± 1 MF	~6321 ± 1 MF	~6320 ± 1 MF	~6321*1 MF
Scan line length & Scan Direction	2 MFs for the scan just prior to the current scan, preempts all video except band 6	~6322 ± 1 MF	~6323 ± 1 MF	~6322 ± 1 MF	~6323*1 MF
Shutter Obscuration	Calibration Shutter (~ 960 MF)	~6384	~7353	~6383	~7383
	Calibration Shutter (Pan Only)	~6390	~7353	~6383	~7383
	Calibration Shutter (Band 4 Only)	~6384	~7325	~6401	~7375
	Calibration Shutter (Band 5 Only)	~6385	~7306	~6418	~7383
	Backup Shutter (~ 780 MF)	~6476	~7256	~6551	~7331
Internal Calibration period	Bands 1-5, 7, Pan	~7123	~7266	~6466	~6619
	Pan Only	~7147	~7266	~6466	~6595
	Band 1 Only	~7143	~7258	~6475	~6597
	Band 2 Only	~7138	~7257	~6477	~6605
	Band 3 Only	~7137	~7248	~6483	~6607
	Band 4 Only	~7135	~7243	~6490	~6610
	Band 7 Only	~7125	~7233	~6498	~6618
	Band 5 Only	~7123	~7229	~6501	~6619
Band 6 Blackbody calibration period	~7112	~7229	~6488	~6612	
DC Restore	Calibration shutter	~6546	~6886	~6899	~7237
	Backup Shutter	~6696	~7039	~6783	~7126
Postamble Data: Vacuum Operation	161 MFs of fill data preempts all Video data except BD 6	~7311 ± 1 MF	~7470 ± 1 MF	~7311 ± 1 MF	~7473 ± 1 MF
Ambient Operation	179 MFs of fill data preempts all Video data except BD 6	~7311 ± 1 MF	~7488 ± 1 MF	~7311 ± 1 MF	~7491 ± 1 MF

TABLE 8. FILL CODE (1 MINOR FRAME)

1A-E	2A-E	3A-E	4A-E	5A-E	6A-E	7A-E	8A-E	9A-E	10A-E	11A-E	12A-E	13A-E	14A-E	15A-E	16A-E
"0"	"0"	"0"	"0"	"0"	"0"	"0"	"0"	"0"	"0"	"0"	"0"	"0"	"0"	"0"	"0"

3.2.5.6.3 DC Restore System (Band 1 through 5, 7 and Pan)

DC restore is a technique for minimizing the effects of low frequency noise and drift. A dark level is applied to the sensors during shutter obscuration to develop a zero clamp level for the analog-to-digital circuitry. This zero clamp level is fractionally updated before each scan to a nominal level of 10 digital counts in the low gain state and 20 digital counts in the high gain state. The zero-clamp level observed during the shutter-closed period should be considered representative of a sensor black-level output during imaging.

The dark condition is established when the shutter blocks the normal optical path for each detector, and is present throughout the obscuration period except during the calibration pulse. Shutter obscuration occurs approximately 0.62 milliseconds after EOL on both forward and reverse scans, and continues for approximately 9.42 milliseconds. Adjustment of the DC restore level lasts approximately 3.25 milliseconds.

3.2.5.6.4 Thermal Band Radiometric Calibration System

A temperature controlled blackbody and a temperature-measured shutter surface provide the calibration reference points for the eight Band 6 detectors. Band 6 detectors view the temperature-measured shutter surface during the DC restore calibration period of each mirror scan. The calibration shutter and blackbody temperatures are measured and inserted into each PCD minor frame (Subcommutation word 72, minor frames 76 and 78, respectively). Absolute calibration will be necessary for the Thermal Infrared band to account for the blackbody shading factor. Compensation for temperature drift and possible emissivity variations may be required throughout the mission.

3.2.5.7 Fill Code Format

Generation of Fill Code begins at 986 minor frames following the transmission of the Scan Line data. The fill code conforms to the Minor Frame Data structure and preempts all minor frame video except Band 6 data. The transmission of fill code continues until the start of the next data word after the next line start pulse is detected (approximately 161 minor frames) in vacuum and 179 minor frames in air. Fill Code will be generated and inserted into each successive minor frame until the occurrence of the next scan line start pulse. The Fill Code will terminate on byte or word boundaries. The number of Fill Code data words will vary with variations in the Scan Line Length. Each of the 16 groups of 5 data words within a given minor frame will contain a single bit binary value (0) that is replicated for all of the bits in the group (40 bits per group). Table 8 lists the single bit values.

3.2.6 PCD/STATUS DATA

For each transfer frame, ten PCD/STATUS' data words shall be provided to accommodate the insertion of payload correction data (PCD) and ETM+ status data into the VCDU Data Zone shown in Figure 12. Table 9–1 shows the format and the data content of the PCD/STATUS' data field. The “msb” is transmitted first. The PCD/Status data, data pointer, data pointer BCH error control, time code data, and scan line data inserted in formats 1 and 2 are identical.

PCD data words contain telemetry information regarding the status of the spacecraft and its subsystems.

3.2.6.1 Status Data Words

Status data words shown in Table 9–1 reflect the current operational status of Landsat 7 subsystems at the start of the first full minor frame (MF) within the VCDU Data Zone. The Status data words shall include a minor frame counter, scan direction, and system status. The minor frame counter represents the minor frame count value (range 0 to 8191 ($1FFF_{16}$)) of the minor frame preceding the first full minor frame of the CADU; that is, a running minor frame counter value for every CADU completed. However, for the CADU in which scan line start occurs, both the minor frame counter and the data pointer (PNTR) may not be valid. The minor frame counter is reset upon detection of scan line start (SLS) and the pointer is resynchronized at the start of the first full minor frame in the subsequent CADU.

TABLE 9-1. PCD/STATUS DATA

WORD #	DATA WORD INFO	DATA WORD FORMAT
1	PCD 1	Bit 1 thru 8 = 1st PCD word (bit 1 = msb)
2	PCD 2	Bit 1 thru 8 = 2nd PCD word (bit 1 = msb)
3	PCD 3	Bit 1 thru 8 = 3rd PCD word (bit 1 = msb)
4	PCD 4	Bit 1 thru 8 = 4th PCD word (bit 1 = msb)
5	MF count (hi)	Bit 1 = scan direction; "0" = Reverse (East to West), "1" = Forward (West to East) Bits 2 and 3 = spare; each set to "0" Bits 4 thru 8 = most significant 5 bits of minor frame count within given scan
6	MF count (low)	Bits 1 thru 8 = least significant 8 bits of minor frame count within given scan
7	System status	Bits 1 thru 3 = MUX Assembly ID; multiplexer assemblies 0 thru 7 identified Bit 4 = Format 1/2 ID; "0" = FMT 1, "1" = FMT 2 Bit 5 = Spare; set to "0" Bit 6 = Shtr 1/2; "0" = CAL Shtr, "1" = Backup Shtr Bit 7 = Spare; set to "0" Bit 8 = PAN band gain; "0" = LO, "1" = HI
8	Band gains	Bits 1 thru 8 correspond respectively to Bands 1 thru 5, Format 1 Band 6, Format 2 Band 6, and Band 7. For each bit, low gain = "0" and high gain = "1".
9	Spare	Bits 1 thru 8 each set to "0" (fill data)
10	Spare	Bits 1 thru 8 each set to "0" (fill data)

Note: The msb is transmitted first

3.2.6.2 The Data PNTR

The AEM PNTR synchronizes the transfer frame timing to minor frame timing. The PNTR indicates the number of data words between the start of the next minor frame following the start of the VCDU Data Unit Zone. The PNTR value is defined as the number of words between the VCDU primary header/ETM+ VCDU Data Block boundary and the minor frame boundary. See Figure 12.

The Scan Mirror Assembly (SMA) generates a sequence of pulses called the SAM Pulse or Scan Angle Monitor Pulses. The pulses are referred to as the Start of Scan Line pulse, Mid Scan pulse and End of Scan Line pulse. The Start of Scan pulse is used to synchronize the AEM. The AEM synchronization (required within 1 μ S) is about one data word or \approx 106.8nS. Upon detection of the Start of Scan pulse, the AEM generates a scan line start pattern described in paragraph 3.2.5.1, in the wideband data stream. The CADU containing the Scan Line Start pattern is called the Scan Line Start CADU.

3.2.6.2.1 Scan Line Pulse

The period variation of the Scan Line Start Pulse can sometimes cause two partial non-contiguous minor frames to be created within the Scan Line Start CADU. This condition is normal and is the result of changes in the SCAN Mirror operational environment and normal wear of the SMA bumpers. During this occurrence, the PNTR value is not guaranteed to be valid for the Scan Line Start CADU; however, for the remaining CADUs within the scan it is guaranteed to be valid.

3.2.6.2.2 *Detecting Scan Line Start*

Scan Line Start must be detected because there are neither status words nor pointers that define where the Scan Line begins. Scan Line Start is detected under the following conditions:

1. Fill Data per paragraph 3.2.5.7 must occur prior to Scan Line Start.
2. The MF counter per Table 9–1 word #5 – 6 will reset to 0 without MF rollover. (MF rollover will occur when the MF counter exceeds 8192 minor frames.)
3. The PNTR Sequence check per 3.2.6.2.3.1.2 and 3.2.6.2.3.2.3 will fail.
4. Scan Line Start pattern per 3.2.5.1 will appear within the VCDU primary header/ETM+ VCDU Data Block boundary. (See Figure 12.)

3.2.6.2.3 *Minor Frame Synchronization Methods*

There are two methods to synchronize the minor frame data. The first is per paragraph 3.2.6.2.3.1 and the second is per paragraph 3.2.6.2.3.2. The differences between both methods are shown in Table 9–2.

TABLE 9–2. COMPARISONS OF SYNCHRONIZATION METHODS

Method	Impact
Minor Frame Data Synchronization without extra zero Detect Condition	Loss of \approx 5MF of 7400MF worth of non-contiguous video data
Minor Frame Data Synchronization with extra zero Detect Condition	Recovering all the non-contiguous video data by detecting and locating extra zero byte (spare word)

3.2.6.2.3.1 **Minor Frame Data Synchronization Without Extra Zero Detect Condition**

3.2.6.2.3.1.1 **PNTR Rollover Correction**

There are only 84 unique states to the PNTR; valid ranges are 0 – 84. PNTR Rollover occurs when the PNTR exceeds 84. Equation 3 per Paragraph 3.2.6.2.5 has to be applied to correct the PNTR to a valid range during rollover, which only occurs during the Scan Line Start CADU.

3.2.6.3.1.2 **PNTR Sequence Computation**

Computation for PNTR sequence may be used to generate and check subsequent PNTRs within the Scan Line. Equation 1 per paragraph 3.2.6.2.5 may be used to calculate the next valid PNTR value.

3.2.6.2.3.1.3 **Minor Frame Data Synchronization**

After detecting a scan line start condition has occurred per paragraph 3.2.6.2.2, search for Scan Line start pattern. The 6 contiguous minor frames following the Scan Line Start will contain Valid Time code. After Extracting Time code discard the remaining 5MF of the MINOR Frames of video data within the CADU. The data discarded represents \approx 5MF of data or less than 0.06% of the MFs in a Scan Line; \approx 7400MF.

3.2.6.2.3.2 **Minor Frame Data Synchronization With Extra Zero Detect Condition**

3.2.6.2.3.2.1 **PNTR Rollover Correction**

There are only 84 unique states to the PNTR; valid ranges are 0 – 84. PNTR Rollover occurs when the PNTR exceeds 84. Equation 1 has to be applied to correct the PNTR to a valid range during rollover, which only occurs during the Scan Line Start CADU.

3.2.6.2.3.2.2 PNTR Correction During Scan Line Start

The first word within the next minor frame boundary is the value of the PNTR+1. In order to determine the PNTR in which Scan Line Start occurs, use the value of the next consecutive PNTR to calculate the previous PNTR using Equation 2 per paragraph 3.2.6.2.5.

3.2.6.2.3.2.3 PNTR Sequence Computation

The Data PNTR follows a defined sequence between scans. Equation 1 may be used to calculate the next valid PNTR value. Upon detecting Scan Line Start the sequence begins by using the next consecutive CADU PNTR.

3.2.6.2.3.2.4 Minor Frame Data Synchronization

The PNTR must first be used to determine where the Minor frame boundary starts. This means that the first word of the minor frame boundary is located at an offset value of PNTR+1 as described in paragraph 3.2.6.2.5. If the Scan Line Start does not begin at the proper location (PNTR+1) then there is an alignment problem and an Extra spare word (Zero) exist within the current CADU containing SLS.

3.2.6.2.3.2.5 Extra Zero Detection

The extra “00”, upon detection of the minor frame misalignment condition as described in paragraph 3.2.6.2.3.2.4 is in offset position Word 975 + the corrected PNTR value within the CADU Virtual Channel Data Unit Zone (VCDU).

Note: Word 975 = 11MFs of 85 words + 40 words of the first half of the MF timing sequence.

3.2.6.2.4 MF Counter

The Minor Frame (MF) differential (Diff) count is related to the data PNTR and may be calculated by Equation 4.

Minor Frame Differential Count = Minor Frame Count (PNTR) – Minor Frame Count (PNTR–1).

If a Scan Line Start is detected within a CADU, the current Minor Frame counter will reset based on the location of the scan line start within the CADU. The new counter is based on the data contained within the next consecutive CADU.

3.2.6.2.5 Equations

The following equations are in decimal number format. The equations for the Next PNTR, previous PNTR, PNTR Rollover correction Calculation and Complete MF differential count are as follows:

Equation 1 Next PNTR Calculation

If PNTR < 47

$$\text{PNTR (x+1)} = \text{PNTR (x)} + 38$$

If PNTR ≥ 47

$$\text{PNTR (x+1)} = \text{PNTR (x)} - 47$$

Equation 2 Previous PNTR Calculation

If $PNTR \geq 38$
 $PNTR(x-1) = PNTR(x) - 38$

If $PNTR < 38$
 $PNTR(x-1) = PNTR(x) + 47$

Equation 3 PNTR Rollover Correction Calculation

If $PNTR \geq 85$
 $PNTR(\text{corrected}) = PNTR(\text{rollover}) - 85$

Equation 4 Complete MF_Diff_Count

If $PNTR = 0$
 MF differential count for number of complete Minor frames = 11

If $PNTR \geq 48$
 MF differential count for number of complete Minor frames = 12

If $PNTR < 48$
 MF differential count for number of complete Minor frames = 11

3.2.7 PCD FORMATS

Payload Correction Data (PCD) contains all data required by ground stations to geometrically correct ETM+ sensor data and redundantly provides the ETM+ imaging configuration. The PCD data is embedded in every wideband data VCDU at a rate of four bytes of PCD per VCDU as shown in Figure 12. The types of PCD data and formatting are provided in this section.

3.2.7.1 Unpacked PCD Format

The PCD data, which is asynchronous with the ETM+, is generated at 4 kbytes/sec. The unpacked PCD format is the PDF data passed to the ETM+ as shown in Figure 18. The 27.765 usec is the period of the ETM+ AEM PCD Read Pulse, while the 250 usec is the duration of the one (1) Data Word cycle generated by the PDF.

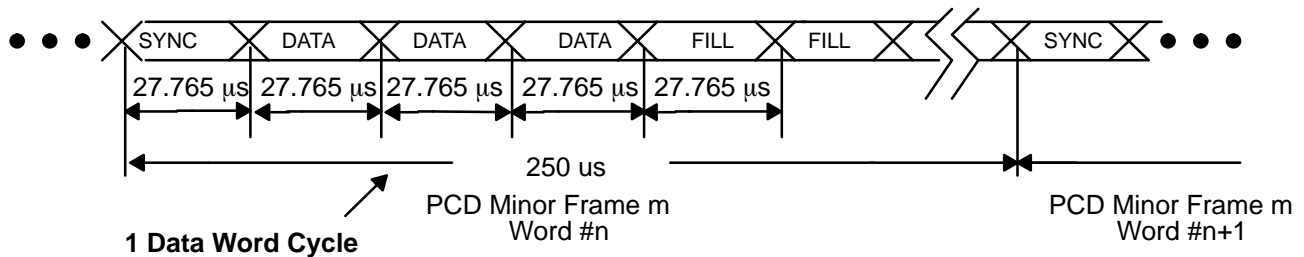

Figure 18. Unpacked PCD Format and Timeline

The PDF utilizes a state machine to perform the transfer of PCD data to the payload. The state machine must be incremented through the five (5) state sequence shown in Figure 18. The sequence, as shown, consists of a Sync word, one valid PCD data word repeated three (3) times, and a Fill word. The fill word remains in the PDF output buffer until the next data word cycle starts, so any further attempt by the payload to read PCD data simply results in another fill word transfer. As a result, a minimum of 9 unpacked words are generated during each PCD data word cycle ($250 \mu\text{sec} / 27.7652 \mu\text{sec} = 9.004077$).

3.2.7.1.1 *Unpacked PCD Definitions*

The unpacked PCD data may consist of three types of eight bit data words: Sync words, data words or Fill data words. The values for these data words are as follows:

1. Sync: 16_{16}
2. Data: $00_{16} \leftrightarrow FF_{16}$
3. Fill: 32_{16}

3.2.7.2 **Packed PCD Format**

The packed PCD format is constructed by ground software, by finding the Sync word in the unpacked data stream, extracting the data words, performing a bit-wise majority rule of the three consecutive unpacked PCD data words to generate one valid PCD data word from the three words, and then storing the selected data into a buffer for interpretation. In the packed format, a complete PCD cycle requires a period of 16.384 seconds. Each PCD cycle is composed of four PCD major frames with each major frame having a period of 4.096 seconds. Cycle refers to a complete set of a PCD table of data.

3.2.7.2.1 *PCD Major Frame*

A PCD major frame consists of 128 PCD minor frames. Each PCD minor frame consists of 128 PCD words. Each PCD major frame therefore contains 16,384 packed PCD data words and nominally (because there are 9.004077 unpacked PCD words/PCD data word cycle) 147,522.80 unpacked PCD words/PCD major frame. Due to the variations of both the spacecraft clock and the PCD major frame clock (derived within the AEM) this can vary between 147,508.05 words and 147,537.55 words. Four PCD major frames are necessary for a PCD Cycle. Figure 19 shows the PCD major frame format. Transmission order is top to bottom, left to right in the major frame format.

3.2.7.3 **PCD Minor Frame**

The PCD minor frame consists of 128 eight bit words as shown in Table 10–1. The majority of these 128 words consist of ADS and Gyro data. Also included are the sync word, minor frame ID MFID, major frame ID and a subcomm word (word 72) as shown in Figure 19. The subcomm words include attitude, gyro drift, ephemeris, time code, ADS Temperature, PCD multiplexer status.

3.2.7.3.1 **PCD Sync**

The PCD sync word identifies the start of the minor frame and it is defined in Table 10–2.

3.2.7.3.2 **PCD Minor Frame ID Counter**

The PCD minor frame ID counter appears in every minor frame in word location 65. The range of the counter is 0 to 127 and is shown in Table 10–3.

3.2.7.3.3 **PCD Major Frame ID**

The PCD Major Frame ID appears in the subcom word in the second, third and fourth major frames and further described in 3.2.7.4.14.

3.2.7.4 **PCD Data Types**

3.2.7.4.1 *Angular Displacement Sensor*

The Angular Displacement Assembly (ADA) consists of three nominally orthogonal Angular Displacement Sensors (ADS). Each ADS of the ADA is sampled every 2 milliseconds during the odd

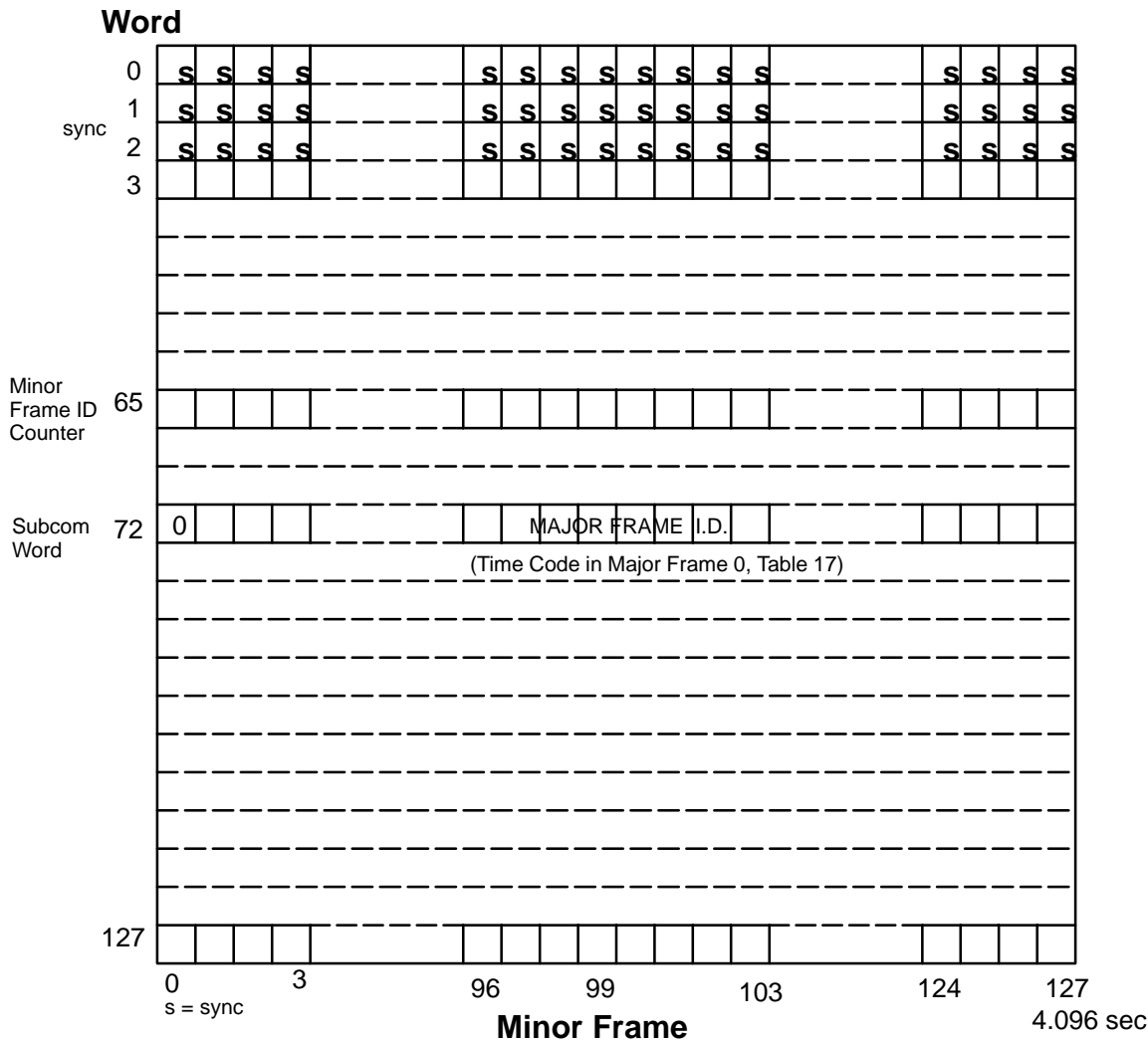

Figure 19. ETM+ PCD Major Frame Format

numbered word time preceding the first of the two data words. The sample is converted to a 12-bit integer value (DN) and then inserted into two (2) consecutive words of a PCD minor frame (refer to Table 10) with the four most significant bits of the first word set to zero. Digital count (0) is the maximum negative angular displacement (-125μ radians) and digital count 4095 is the maximum positive angular displacement ($+125 \mu$ radians). The least significant bit of each count is nominally $125/2^{11}$ microradians. The nominal zero angular displacement output of any ADS is 2048 counts. There are 8192 samples of each ADS in a PCD cycle. The most significant bit is transmitted first. Calibration curve = $-125 + (DN \cdot 125/2^{11})$ to convert to microradians.

3.2.7.4.2 ADS Temperature

Up to four ADS-related temperatures will be sampled once a PCD major frame (every 4.096 seconds). Each sample will be converted to a 12 bit word and inserted in 2 consecutive words of format, with the 4 msb's of the first word set to zero, as show in Table 11. The data will be sampled in the word time preceding the data word. That is, ADS Temperature #1 is placed in word 72 minor frame 108 and 109 and sampling time is during word 71 of minor frame 108. The formatting and range of ADS temperature data is shown in Table 11.

TABLE 10-1. PCD TYPICAL MINOR FRAME

DATA	MINOR FRAME WORD NUMBER	DATA	MINOR FRAME WORD NUMBER
Sync	0,1,2	MFID CTR	65
ADS-X	3,4	ADS-X	66,67
ADS-Y	5,6	ADS-Y	68,69
ADS-Z	7,8	ADS-Z	70,71
0 Filled	9	Sub Comm	72
0 Filled	10	0 Filled	73
ADS-X	11,12	ADS-X	74,75
ADS-Y	13,14	ADS-Y	76,77
ADS-Z	15,16	ADS-Z	78,79
Gyro	17	0 Filled	80
0 Filled	18	Gyro	81
ADS-X	19,20	ADS-X	82,83
ADS-Y	21,22	ADS-Y	84,85
ADS-Z	23,24	ADS-Z	86,87
0 Filled	25,26	0 Filled	88,89
ADS-X	27,28	ADS-X	90,91
ADS-Y	29,30	ADS-Y	92,93
ADS-Z	31,32	ADS-Z	94,95
Gyro	33	0 Filled	96
0 Filled	34	Gyro	97
ADS-x	35,36	ADS-X	98,99
ADS-Y	37,38	ADS-Y	100,101
ADS-Z	39,40	ADS-Z	102,103
0 Filled	41,42	0 Filled	104,105
ADS-X	43,44	ADS-X	106,107
ADS-Y	45,46	ADS-Y	108,109
ADS-Z	47,48	ADS-Z	110,111
Gyro	49	0 Filled	112
0 Filled	50	Gyro	113

TABLE 10-1. PCD TYPICAL MINOR FRAME (CONT)

DATA	MINOR FRAME WORD NUMBER	DATA	MINOR FRAME WORD NUMBER
ADS-X	51,52	ADS-X	114,115
ADS-Y	53,54	ADS-Y	116,117
ADS-Z	55,56	ADS-Z	118,119
0 Filled	57,58	0 Filled	120,121
ADS-X	59,60	ADS-X	122,123
ADS-Y	61,62	ADS-Y	124,125
ADS-Z	63,64	ADS-Z	126,127

TABLE 10-2. PCD MINOR FRAME SYNC FORMAT

WORD	BCD CODE	HEX CODE
0	(msb) 1111 1010 (lsb)	FA
1	1111 0011	F3
2	0010 0000	20

TABLE 10-3. PCD MINOR FRAME IDENTIFIER

DATA WORD	BIT (msb) 0 1 2 3 4 5 6 7 (lsb)
65	I ₀ , I ₁ , I ₂ , I ₃ , I ₄ , I ₅ , I ₆ , I ₇

I₀ = 0 at all times.

I₁- I₇ = Binary count from 0₁₀ to 127₁₀ (msb - lsb)

3.2.7.4.3 Gyro Data

The inertial measurement unit (IMU) consists of three, two-degree-of-freedom gyros. The spacecraft maintains 24 bit pulse accumulators for each gyro axes (XA, XB, YA, YB, ZA, ZB). The gyro pulse counts from each of three selected accumulators are sampled every 64 milliseconds. The spacecraft provides one data value for each IMU axis in the PCD. The IMU generates a signed pulse for each 0.061 arc-sec of angular motion. A positive pulse increments a 24-bit register and a negative pulse decrements the register. A positive pulse is generated by a positive rotation about the gyro axis. The pitch orbital motion and gyro drift cause the register to periodically overflow. The register is reset to zero when its value is positive $2^{23}-1$ and a positive pulse is received, or when its value is negative 2^{23} and a negative pulse is received. Each axis is sampled at the same time. There are 256 samples of each IMU axis during a PCD cycle. The sample timing is as follows:

Let the gyro samples for any one axis appearing in a PCD cycle (16.384 seconds) be numbered N = 0, 1, ..., 255. Then the time for each sample is the PCD time code plus (64N) milliseconds.

TABLE 11. ADS/PDF TEMPERATURES

		WORD 72 MINOR FRAMES	DATA WORD	SAMPLED DURING WORD
Temp 1	(ADS-X)	108 109	(msb) 0000XXXX XXXXXXXXX (lsb)	71 (108)
Temp 2	(ADS-Y)	110 111	(msb) 0000XXXX XXXXXXXXX (lsb)	71 (110)
Temp 3	(ADS-Z)	112 113	(msb) 0000XXXX XXXXXXXXX (lsb)	71 (112)
Temp 4	PDF Analog Temperature	114 115	(msb) 0000XXXX XXXXXXXXX (lsb)	71 (114)

Applies to the four temperature sensors:
 Range = +50°C = 0000₁₆ to 0°C = OFFF₁₆.
 lsb = 0.0122°C (4096/50)

Each data value consists of a 23-bit value which is provided in the PCD as three, eight-bit words. The data are in two's complement format with the msb first. Figure 20 shows the format of the gyro data and its position in the PCD. Note, the gyro data is in the IMU reference frame. The relationship between the IMU reference frame and the satellite Navigational Reference Frame for each gyro axis is defined in the Landsat 7 Program Coordinate System Standard, 23007610.

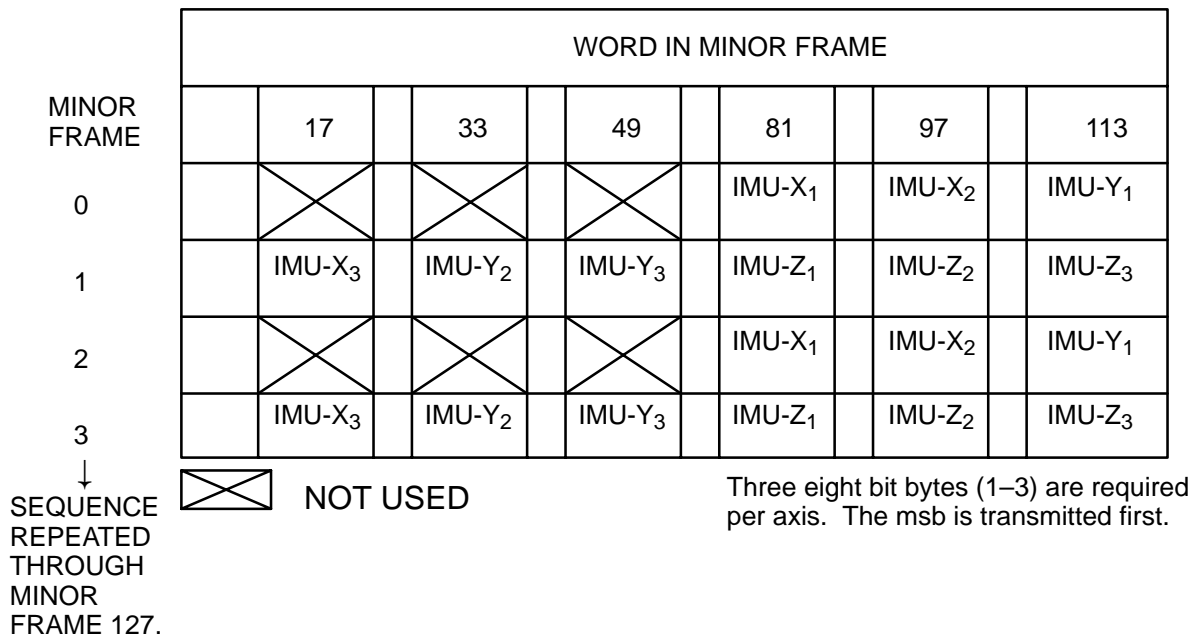

Figure 20. PCD Gyro Data

3.2.7.4.4 Gyro Drift Data

The gyro drift calculation is performed based upon asynchronous star sightings and are presented in the PCD subcomm word 72 for PCD major frame (0) and calculated at the PCD cycle time code (TC) minus 8.192 seconds. Gyro drift is calculated in the navigation axis coordinate system. The Units of gyro drift rate are radians/sec and the data are calibrated at an lsb weight of 2^{-47} . The format and frame position of the gyro drift binary 2s complement integer data is shown in Figure 21. Accurate data are available when PRADS is converged. If PRADS is both not running nor converged gyro drift data are not valid.

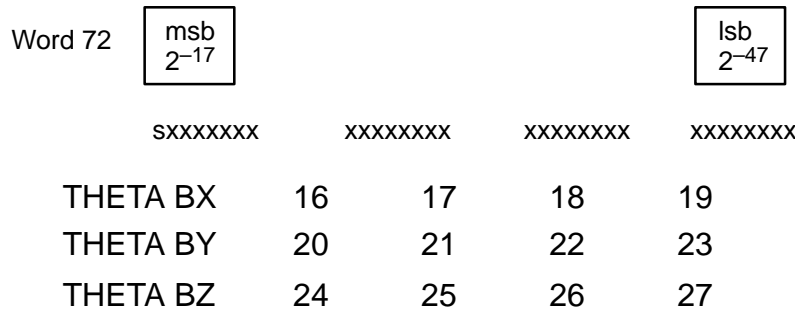

Figure 21. Gyro Drift Data

The gyro drift data will appear in word 72 of minor frames 16 through 27 of PCD major frame zero.

3.2.7.4.5 Attitude Estimate

The spacecraft calculates an estimate of the attitude, represented as Euler parameters. The Euler Parameters are labeled EPA1, EPA2, EPA3, and EPA4 and are components of the quaternion defining the rotation. Components 1 through 3 define the eigen-axis of rotation in Earth Centered Inertial (ECI) coordinates, and component 4 defines the rotation about that axis. Euler double precision words are scaled to 32 bits in two's complement form as shown in Figure 22. Accurate data are available when PRADS is running and converged. If PRADS is not running, backup (YGC) data will be provided.

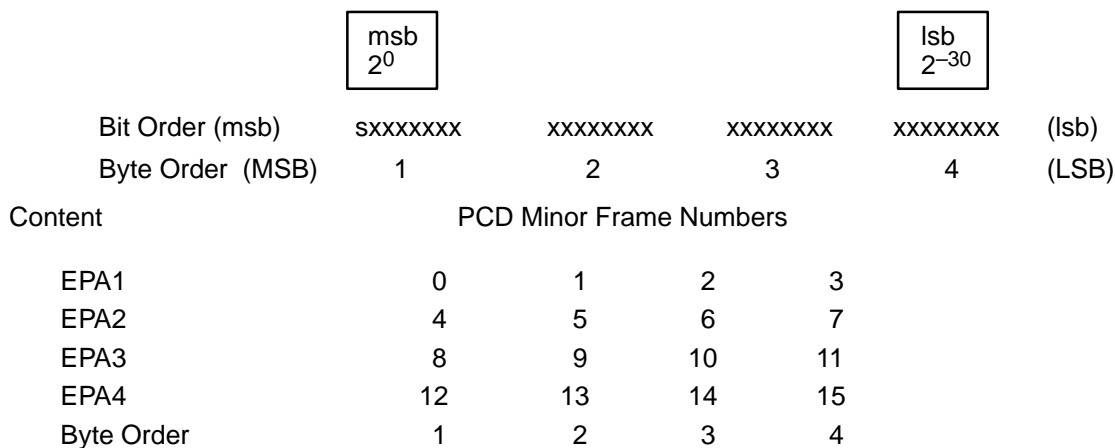

Figure 22. Attitude Estimate

Four Euler Parameters (EPA's) are output in word 72 of minor frames 0 through 15 of each PCD Major Frame. The time associated with attitude data contained within the PCD can be derived from the time code contained in words 96 through 102 of the first PCD major frame in the cycle. The attitude data time is derived as follows:

The output sequence is shown in Figure 22. The most significant bit is transmitted first.

3.2.7.4.6 Time of Last (SV) Space Vehicle Clock Update

The time of the last SV clock update is inserted in the PCD stream. The SV clock is typically updated by the MOC once per day, and during ETM+ non-imaging periods. The bit format is a 48-bit extended precision floating point value in seconds from midnight of the first day of the year as shown in Figure 23 (See MIL-STD-1750A). The 48 bits of last SV clock update are subcommutated into word 72 of Minor Frames 28 thru 33 of the first PCD major frame in the PCD cycle.

PCD
Major Frame Number Time Computation

0	PCD time code – 8.192 seconds
1	PCD time code – 4.096 seconds
2	PCD time code + 0.000 seconds
3	PCD time code + 4.096 seconds

MF No. DESCRIPTION

28	First 8 bits of the time of the last SV clock parameter upload (msb)
29	Second 8 bits of the time of the last SV clock parameter upload
30	Third 8 bits of the time of the last SV clock parameter upload
31	Fourth 8 bits of the time of the last SV clock parameter upload
32	Fifth 8 bits of the time of the last SV clock parameter upload
33	Sixth 8 bits of the time of the last SV clock parameter upload (lsb)

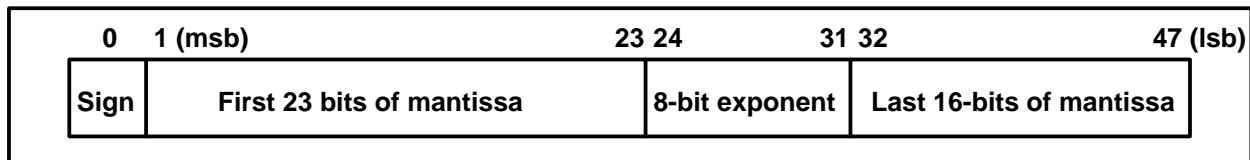

Figure 23. SCP Representation of a 48-bit Extended Floating Point Word

3.2.7.4.7 SV Time Drift Characterization Data

The S/C Time Drift Characterization Data is used on the ground, along with the Time of Last S/C Clock Update, to correct the spacecraft time, reported in the PCD and video, for clock drift, to within ± 15 milliseconds of UTC. The SV time drift characterization data is updated by the MOC daily, and at the same time as the SV clock update data during ETM+_non-imaging periods. The corrected time is calculated according to the following equation:

$$\Delta t = t_{s/c} - t_{update}$$

$$T_c = t_{s/c} + C_0 + C_1 \Delta t + 0.5 C_2 \Delta t^2$$

where:

- Δt = the spacecraft clock time relative to the last clock update
- T_c = the spacecraft corrected time (approx. UTC, ± 15 milliseconds)
- $t_{s/c}$ = a spacecraft clock time; the clock time for ephemeris calculations is the time of 2 Hz cycle that the spacecraft state is referenced to
- t_{update} = the spacecraft clock time of the last ground commanded clock update
- C_0 = the clock correction bias term – can be used to minimize the clock error over some span of time; may be set to zero if not needed
- C_1 = the clock correction first order coefficient (drift rate)
- C_2 = the clock correction second order coefficient (drift acceleration); may be set to zero if not needed

The 32 bits of S/C Time Drift Characterization Data are subcommutated into word 72 of Minor Frames 36–41 of the first PCD Major Frame in the PCD cycle. The msb is transmitted first.

MF No.	DESCRIPTION	
36	First 8 bits of the clock correction bias term (msb)	} msec.
37	Second 8 bits of the clock correction bias term (lsb)	
38	First 8 bits of the clock correction first order coefficient (drift rate) (msb)	} msec./day
39	Second 8 bits of the clock correction first order coefficient (drift rate) (lsb)	
40	First 8 bits of the clock correction second order coefficient (drift accel) (msb)	} msec./day ²
41	Second 8 bits of the clock correction second order coefficient (drift accel)(lsb)	

3.2.7.4.8 Ephemeris

Four ephemeris points are provided by the spacecraft during a PCD cycle and inserted into the PCD stream. The ephemeris entry consists of six components: Position coordinates X, Y, and Z in kilometers and Velocity components X', Y', and Z' in kilometers per second. The coordinate system is the J2000 and is defined in PS23007610 Program Coordinates System Standard (PCSS). These calculations are performed at the same time as the Euler Parameter attitude estimate calculation.

Ephemeris data are 32 bit, two's complement, binary numbers. The range of the Position component is $\pm 8.3886 \times 10^6$ meters and the range for the Velocity component is ± 8.0 meters/millisecond. The value of the least significant bit is 2^{-8} meters for position and 2^{-28} meters/millisecond for velocity. The format of this data is shown in Figure 24.

The time associated with ephemeris data contained within the PCD can be derived from the time code contained in words of minor frame 96 through 103 of the first PCD major frame in the PCD cycle. The Ephemeris data time is derived as follows:

PCD Major Frame Number	Time Computation
0	PCD time code - 8.192 seconds
1	PCD time code - 4.096 seconds
2	PCD time code + 0.000 seconds
3	PCD time code + 4.096 seconds

The data will appear in word 72 of minor frames 50 through 73 for Major Frames (0) and (2) and minor frames 16 through 39 for Major Frames (1) and (3). The msb is transmitted first.

3.2.7.4.9 ETM+ Telemetry Data

A total of 688 bits of ETM+ telemetry data are inserted into the PCD. The data appears in word 72 of minor frames 16 through 49 of PCD major frame two (2), minor frames 74 through 83 of every major frame and PCD major frame two (2), minor frame word 84. The ETM+ telemetry words which occur in Minor Frames 16 through 49 are sampled approximately once every 16.384 seconds. The ETM+ telemetry words 74 through 80 are sampled by the SCP approximately every 4.096 seconds, then inserted into the next major frame. All other ETM+ telemetry data is sampled approximately every 16.384 seconds including serial word "P" in minor frame word 84 of PCD major frame two (2).

Ephemeris in Major Frames (0) and (2)

Position Components

Word 72	MSB 2^{22}			LSB 2^{-8}	
	SXXXXXXXX	XXXXXXXXX	XXXXXXXXX	XXXXXXXXX	
X		50	51	52	53
Y		54	55	56	57
Z		58	59	60	61
					Minor Frame

Velocity Components

Word 72	MSB 2^2			LSB 2^{-28}	
	SXXXXXXXX	XXXXXXXXX	XXXXXXXXX	XXXXXXXXX	
X		62	63	64	65
Y		66	67	68	69
Z		70	71	72	73
					Minor Frame

Ephemeris in Major Frames (1) and (3)

Position Components

Word 72	MSB 2^{22}			LSB 2^{-8}	
	SXXXXXXXX	XXXXXXXXX	XXXXXXXXX	XXXXXXXXX	
X		16	17	18	19
Y		20	21	22	23
Z		24	25	26	27
					Minor Frame

Velocity Components

Word 72	MSB 2^2			LSB 2^{-28}	
	SXXXXXXXX	XXXXXXXXX	XXXXXXXXX	XXXXXXXXX	
X		28	29	30	31
Y		32	33	34	35
Z		36	37	38	39
					Minor Frame

Figure 24. PCD Ephemeris Data

3.2.7.4.10 *Spacecraft ID and Time Code*

Fifty-six bits of spacecraft ID and time code (seven 8-bit words) are inserted in the PCD stream. This code represents the start time for PCD Major Frame (0) and provides the timing reference for all data in the PCD cycle. The 56 bits of spacecraft time code are subcommutated into word 72 of Minor Frames 96 through 102 of PCD Major Frame (0) in the PCD cycle. The output sequence for the 52 time code bits is contained in Table 12. The 4-bit spacecraft ID is (111₂). The msb is transmitted first. The binary coded decimal (BCD) days field possible range is 0 to 999, hours (0 to 23, minutes (0 to 59), seconds (0 to 59), milliseconds (0 to 999), and binary coded fractional milliseconds with bit values of the fractional milliseconds having values of 1/2, 1/4, 1/8, and 1/16 milliseconds. The day field range is nominally from 001 to 365 or 366 for a leap year and controlled by the the Mission Operations Center.

3.2.7.4.11 *Multiplexer Status*

The multiplexer gain state is provided in the ETM+ telemetry PCD data. This data is located in Word 72 of Minor frames 82 and 83 of the second Major Frame (Major Frame (1)).

TABLE 12. PCD TIME CODE

MINOR FRAME NUMBER	TIME CODE WORD NUMBER	WORD 72 BITS 0-7	CONTENT OF WORD 72
96	1	(msb) 0-3 4-7 (lsb)	SPACECRAFT ID HUNDREDS OF DAYS
97	2	0-3 4-7	TENS OF DAYS UNITS OF DAYS
98	3	0-3 4-7	TENS OF HOURS UNITS OF HOURS
99	4	0-3 4-7	TENS OF MINUTES UNITS OF MINUTES
100	5	0-3 4-7	TENS OF SECONDS UNITS OF SECONDS
101	6	0-3 4-7	HUNDRED OF MILLISECONDS TENS OF MILLISECONDS
102	7	0-3 4-7	UNITS OF MILLISECONDS FRACTIONS OF MILLISECONDS (LSB=1/16 MILLISECOND)

3.2.7.4.12 *PDF A/D Ground Reference*

The output of the Angular Displacement Assembly (ADA) A/D converter for a grounded input is transmitted in word 72 of minor frames 116 and 117 of each PCD Major Frame. Note that the MSB of minor frame 116 will always be set to "1". An internally generated ground reference signal is sampled and formatted as shown in Table 13. The msb is transmitted first.

TABLE 13. PDF GROUND REFERENCE TELEMETRY

MINOR FRAME	DATA WORD	BIT (msb) 01234567 (lsb)	SAMPLED DURING WORD
116	72	1000 G ₀ G ₁ G ₂ G ₃	71 (116)
117	72	G ₄ G ₅ G ₆ G ₇ G ₈ G ₉ G ₁₀ G ₁₁	71 (116)
G ₀ -G ₁₁ = Ground Reference Bits (msb-lsb)			

3.2.7.4.13 Minor Frame Sync

The same sync pattern will appear in words 0 through 2 of each PCD minor Frame as shown in Table 10-2.

3.2.7.4.14 Major Frame Identification

Word 72 of minor frames 96 through 103 of the second, third, and fourth PCD major Frames will contain the unique identifier, “1”, “2”, “3” as in Table 14. The time code is in major frame zero (0).

TABLE 14. PCD MAJOR FRAME IDENTIFIER

PCD MAJOR FRAME	8-BIT IDENTIFIER
1	(msb) 0000 0001 (lsb)
2	0000 0010
3	0000 0011

3.2.7.4.15 Attitude Control System Mode

The attitude control system mode is contained in word 72 of minor frame 84 in the fourth major frame of each PCD cycle. This data provides an indication of the CPU mode which is an indication of whether or not the spacecraft attitude is being precision controlled to within the 0.05 degree pointing accuracy. Table 15 shows the CPU modes and word values. The msb is transmitted first. These modes will be described in the following paragraphs.

TABLE 15. ATTITUDE CONTROL SYSTEM MODES

WORD	CPU MODE
(msb) 00000010 (lsb)	Precision (Primary)
(msb) 00001000 (lsb)	Yaw Gyro Compassing (YGC) (Backup)

3.2.7.4.15.1 Precision (Primary)

The computer supplying the PCD is controlling the spacecraft attitude. All ephemeris, attitude, and gyro drift data represent the desired 0.05 degree pointing accuracy.

3.2.7.4.15.2 YGC (Backup)

The computer supplying the PCD is controlling the spacecraft attitude. Attitude and gyro drift data represent 0.2 degree pointing accuracy in pitch and roll and 1.5 degrees in yaw. The spacecraft attitude is not being precision controlled.

3.2.7.4.16 ETM+ On/Off Times

The PCD contains the Last ETM+ On Time and the Last ETM+ Off Time parameters. One of these times is updated each time an On or Off transition is executed by the ETM+. When the ETM+ power supply 1 (A or B) current is greater than or equal to 0.4 amperes and power supply 2 (A or B) current is greater than or equal to 0.4 amperes, the ETM+ is on, the Last ETM+ On time stamp is updated and the data appears in ETM+ major frame (0) word 72, minor frame 42 through 47. When the ETM+ power supply 1 (A and B) current is less than 0.4 amperes or power supply 2 (A and B) current is less than 0.4 amperes, the ETM+ is off, the Last ETM+ Off Time stamp is updated and the data appears in ETM+ major frame (0) word 72, minor frame 84 through 89. The bit pattern for the ETM+ On and Off time code is identical to that in 3.2.7.4.6. The spacecraft controls processor monitors the ETM+ power supply current telemetry every 4 seconds at the 4,096 bps narrowband telemetry rate. Flight software checks for a change in the On/Off state of the ETM+ every PDF major frame (every 4.096 seconds). ETM+ On/Off times are sent in PCD once per PDF cycle (every 16.384 seconds) in major frame (0).

3.2.7.4.17 Gyro Select Data

The PCD subcom word 72 of major frame 0, location word 34 contains gyro channel select data (XA, XB, YA, YB, ZA and XB) in bits 0, 1 and 2. These bits indicate the gyro data counts that are provided in the PCD by the PDF. The remaining five bits are not used. The bit values and meanings are in Table 16.

TABLE 16. GYRO SELECT BIT CODING

Bit	Value	Information
0 (msb)	1	XA Gyro Selected
0	0	XB Gyro Selected
1	1	YA Gyro Selected
1	0	YB Gyro Selected
2	1	ZA Gyro Selected
2	0	ZB Gyro Selected
3-7 (lsb)	0's	Zero Fill

3.2.7.4.18 ETM+ Bands On Flags

The ETM+ bands on-flags in major frame 2, minor frame 32, word 72, bits 0-6 and major frame 2, minor frame 35, word 72, bit 0 appear in the PCD every 16.384 seconds. Typically these are set prior to the imaging interval. However, if the bands are turned off or on during the imaging interval, the SCP receives the ETM+ band flag data from the S-Band telemetry data formatter at a subcom rate equivalent to 16.384 seconds, and not related to the time code contained in the PCD.

3.2.7.4.19 ETM+ Calibration Lamp Current Telemetry

Calibration lamp currents (1 and 2) and the active MUX temperatures will be in the PCD if the spacecraft has been commanded to do so. A Telemetry Data Formatter (TDF) patch is required by the ground to implement this capability. Ground processing is based upon which TDF patch is applied. If the TDF patch is not applied, for whatever reason, the default MUX temperature slots apply.

If the TDF RAM patch is not applied, the default is MUX 2 temperature in ‘major frame 0, word 72, minor frame 83 [Mux 2 Electronics Temperature]’ and ‘major frame 1, word 72, minor frame 81 [Mux 2 Power Supply Temperature]’, respectively; and MUX1 temperatures in ‘major frame 0, word 72, minor frame 81 [Mux 1 Electronics Temperature]’ and ‘minor frame 82 [Mux 1 Power Supply Temperature]’, respectively.

If the TDF RAM patch is applied, the two calibration lamp currents (1 and 2) are placed in ‘major frame 1, word 72, minor frame 81 [Cal Lamp 1 Current]’ and ‘major frame 0, word 72, minor frame 83 [Cal Lamp 2 Current]’, respectively; and the active MUX (1 or 2) temperatures are placed in ‘major frame 0, word 72, minor frame 81 [MUX 1/2 Electronic Temperature]’ and ‘minor frame 82 [MUX 1/2 Power Supply Temperature]’, respectively.

Since PCD contents of ‘major frame 0, word 72, minor frames 81, 82 and 83’ and ‘major frame 1, word 72, minor frame 81’ depend on spacecraft commanding, Table 17 contains an “or” for whether or not the patch as been applied.

3.2.7.4.20 Payload Correction Data (PCD) Latencies

PCD total latencies for 1 Kbps and 4 Kbps housekeeping telemetry data rates are in Appendix C, for both TDF and Flight Software originated data.

3.2.7.5 Subcommutation Word 72

Since word 72 of all PCD Minor Frames contain a variety of data essential to the ground segment image processing, Table 17 through Table 20 and Figure 23 through Figure 26 are provided for illustration. Descriptions of the data contained within this word are contained in the previous paragraphs and in the on-orbit handbook. Minor frames 0 through 95 are supplied from the SCP via the CIU to the PDF, including zero fill, for the four major frames (0, 1, 2 and 3) word 72.

TABLE 17. ETM+ PCD MAJOR FRAME (0) WORD 72

MINOR FRAME	DESCRIPTION
0	Euler Parameter 1 (EPA 1)
1	Euler Parameter 1 (EPA 1)
2	Euler Parameter 1 (EPA 1)
3	Euler Parameter 1 (EPA 1)
4	Euler Parameter 2 (EPA 2)
5	Euler Parameter 2 (EPA 2)
6	Euler Parameter 2 (EPA 2)
7	Euler Parameter 2 (EPA 2)
8	Euler Parameter 3 (EPA 3)
9	Euler Parameter 3 (EPA 3)
10	Euler Parameter 3 (EPA 3)
11	Euler Parameter 3 (EPA 3)
12	Euler Parameter 4 (EPA 4)
13	Euler Parameter 4 (EPA 4)
14	Euler Parameter 4 (EPA 4)
15	Euler Parameter 4 (EPA 4)
16	Theta BX
17	Theta BX
18	Theta BX
19	Theta BX
20	Theta BY
21	Theta BY
22	Theta BY
23	Theta BY
24	Theta BZ
25	Theta BZ
26	Theta BZ
27	Theta BZ
28	First 8 bits of last SV clock update
29	Second 8 bits of last SV clock update
30	Third 8 bits of last SV clock update
31	Fourth 8 bits of last SV clock update
32	Fifth 8 bits of last SV clock update
33	Sixth 8 bits of last SV clock update
34	Gyro Select Data
35	Zero Fill
36-41	SV Clock Drift

TABLE 17. ETM+ PCD MAJOR FRAME (0) WORD 72 (CONT)

MINOR FRAME	DESCRIPTION
42	First 8 bits of the time of the last ETM+On Time
43	Second 8 bits of the time of the last ETM+On Time
44	Third 8 bits of the time of the last ETM+On Time
45	Fourth 8 bits of the time of the last ETM+On Time
46	Fifth 8 bits of the time of the last ETM+On Time
47	Sixth 8 bits of the time of the last ETM+On Time
48-49	Zero Fill
50	X - Position
51	X - Position
52	X - Position
53	X - Position
54	Y - Position
55	Y - Position
56	Y - Position
57	Y - Position
58	Z - Position
59	Z - Position
60	Z - Position
61	Z - Position
62	X - Velocity
63	X - Velocity
64	X - Velocity
65	X - Velocity
66	Y - Velocity
67	Y - Velocity
68	Y - Velocity
69	Y - Velocity
70	Z - Velocity
71	Z - Velocity
72	Z - Velocity
73	Z - Velocity
74	Black Body Temperature (Isolated)
75	CFPA Heater Current
76	Calibration Shutter Flag Temperature
77	Backup Shutter Flag Temperature
78	Black Body Temperature (Control)
79	Baffle Temperature (Heater)

TABLE 17. ETM+ PCD MAJOR FRAME (0) WORD 72 (CONT)

MINOR FRAME	DESCRIPTION
80	CFPA Control Temperature
81	Mux 1 or 2 Electronic Temperature (after TDF RAM Patch applied) or Mux 1 Electronics Temperature (default, no patch)
82	Mux 1 or 2 Power Supply Temperature (after TDF RAM Patch applied) or Mux 1 Power Supply Temperature (default, no patch)
83	Cal Lamp 2 Current (after TDF RAM Patch applied) or Mux 2 Electronics Temperature (default, no patch)
84	First 8 bits of the time of the last ETM+Off Time
85	Second 8 bits of the time of the last ETM+Off Time
86	Third 8 bits of the time of the last ETM+Off Time
87	Fourth 8 bits of the time of the last ETM+Off Time
88	Fifth 8 bits of the time of the last ETM+Off Time
89	Sixth 8 bits of the time of the last ETM+Off Time
90-95	Zero Fill
96	Bits 0-3 = Spacecraft ID; Bits 4-7 = Hundreds of Days
97	Bits 0-3= Tens of Days; Bits 4-7 = Units of Days
98	Bits 0-3= Tens of Hours; Bits 4-7= Units of Hours
99	Bits 0-3 = tens of Minutes; Bits 4-7 = Units of Minutes
100	Bits 0-3 = Tens of Seconds; Bits 4-7 = Units of Seconds
101	Bits 0-3 = Hundreds of Milliseconds; Bits 4-7 = tens of Milliseconds
102	Bits 0-3 = Units of Milliseconds; Bits 4-7 = Fractions of Milliseconds
103	Bits 0-8 = Zeroes
104-107	Zero Fill
108	Bits 0-3 = 0000 ; Bits 4-7 = ADS-X Temp 1
109	ADS-X Temp 1
110	Bits 0-3 = 0000 ; Bits 4-7 = ADS-Y Temp 2
111	ADS-Y Temp 2
112	Bits 0-3 = 0000 ; Bits 4-7 = ADS-Z Temp 3
113	ADS-Z Temp 3
114	Bits 0-3 = 0000 ; Bits 4-7 = A/D Temp - ADS Electronics
115	A/D Temp - ADS Electronics
116-117	A/D Ground Reference
118-127	Zero Fill

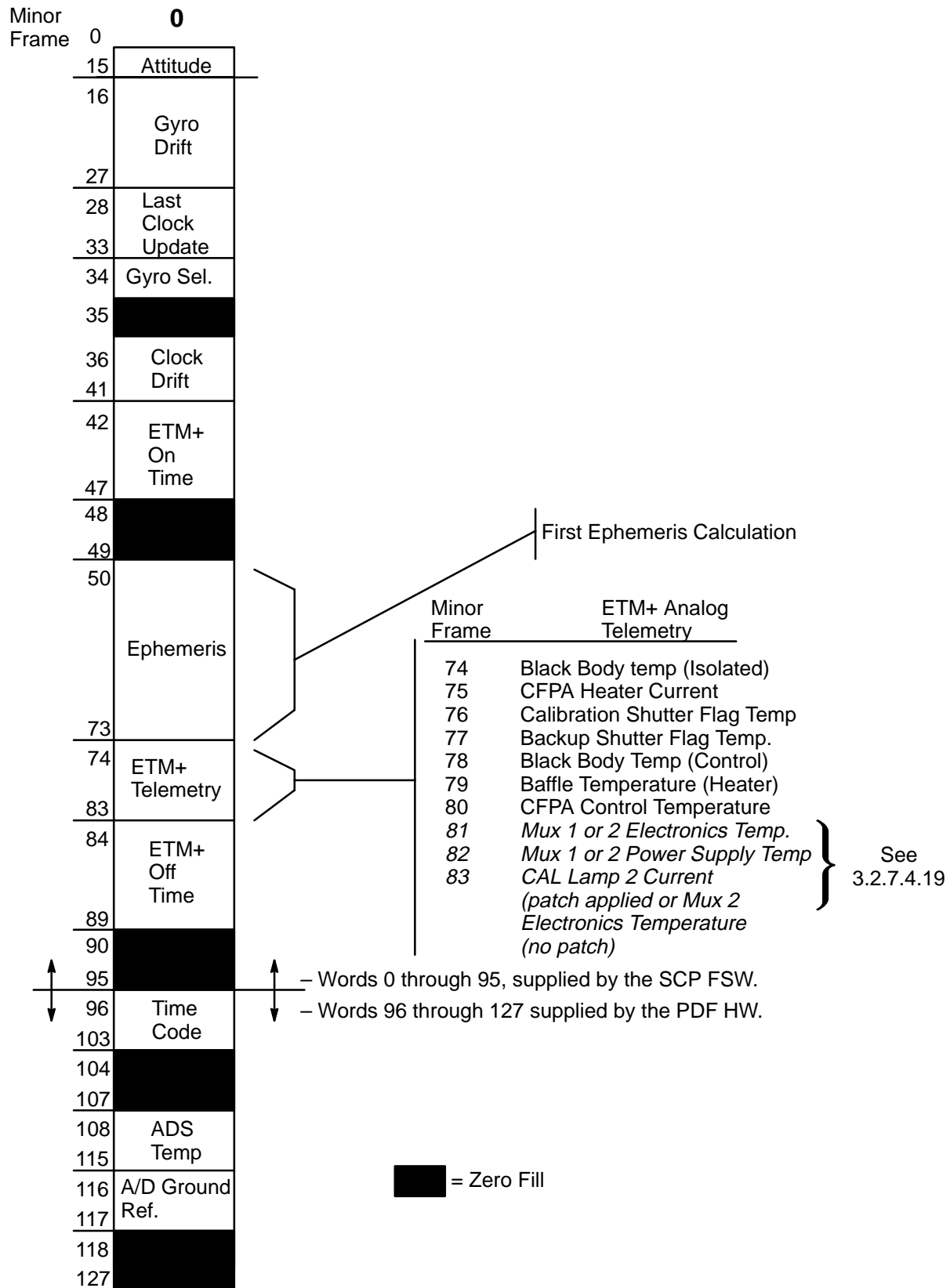

Figure 25. PCD Subcommutation Major Frame (0) Word 72

TABLE 18. ETM+ PCD MAJOR FRAME (1) WORD 72

MINOR FRAME	DESCRIPTION
0	Euler Parameter 1 (EPA 1)
1	Euler Parameter 1 (EPA 1)
2	Euler Parameter 1 (EPA 1)
3	Euler Parameter 1 (EPA 1)
4	Euler Parameter 2 (EPA 2)
5	Euler Parameter 2 (EPA 2)
6	Euler Parameter 2 (EPA 2)
7	Euler Parameter 2 (EPA 2)
8	Euler Parameter 3 (EPA 3)
9	Euler Parameter 3 (EPA 3)
10	Euler Parameter 3 (EPA 3)
11	Euler Parameter 3 (EPA 3)
12	Euler Parameter 4 (EPA 4)
13	Euler Parameter 4 (EPA 4)
14	Euler Parameter 4 (EPA 4)
15	Euler Parameter 4 (EPA 4)
16	X-Position
17	X-Position
18	X-Position
19	X-Position
20	Y-Position
21	Y-Position
22	Y-Position
23	Y-Position
24	Z-Position
25	Z-Position
26	Z-Position
27	Z-Position
28	X-Velocity
29	X-Velocity
30	X-Velocity
31	X-Velocity
32	Y-Velocity
33	Y-Velocity
34	Y-Velocity
35	Y-Velocity
36	Z-Velocity

TABLE 18. ETM+ PCD MAJOR FRAME (1) WORD 72

MINOR FRAME	DESCRIPTION																		
37	Z-Velocity																		
38	Z-Velocity																		
39	Z-Velocity																		
40-73	Zero Fill																		
74	Black Body Temperature (Isolated)																		
75	CFPA Heater Current																		
76	Calibration Shutter Flag Temperature																		
77	Backup Shutter Flag Temperature																		
78	Black Body Temperature (Control)																		
79	Baffle Temperature (Heater)																		
80	CFPA Control Temperature																		
81	Cal Lamp 1 Current (after TDF Patch applied) or Mux 2 Power Supply Temperature (default, no patch)																		
82	<table border="0"> <tr> <td>Serial Word "J"</td> <td>Bit</td> </tr> <tr> <td>AEM Multiplexer 1 BAND 1 Gain State</td> <td>0</td> </tr> <tr> <td>AEM Multiplexer 1 BAND 2 Gain State</td> <td>1</td> </tr> <tr> <td>AEM Multiplexer 1 BAND 3 Gain State</td> <td>2</td> </tr> <tr> <td>AEM Multiplexer 1 BAND 4 Gain State</td> <td>3</td> </tr> <tr> <td>AEM Multiplexer 1 BAND 5 Gain State</td> <td>4</td> </tr> <tr> <td>AEM Multiplexer 1 BAND 6 PRI Gain State</td> <td>5</td> </tr> <tr> <td>AEM Multiplexer 1 BAND 7 Gain State</td> <td>6</td> </tr> <tr> <td>AEM Multiplexer 1 BAND P Gain State</td> <td>7</td> </tr> </table>	Serial Word "J"	Bit	AEM Multiplexer 1 BAND 1 Gain State	0	AEM Multiplexer 1 BAND 2 Gain State	1	AEM Multiplexer 1 BAND 3 Gain State	2	AEM Multiplexer 1 BAND 4 Gain State	3	AEM Multiplexer 1 BAND 5 Gain State	4	AEM Multiplexer 1 BAND 6 PRI Gain State	5	AEM Multiplexer 1 BAND 7 Gain State	6	AEM Multiplexer 1 BAND P Gain State	7
Serial Word "J"	Bit																		
AEM Multiplexer 1 BAND 1 Gain State	0																		
AEM Multiplexer 1 BAND 2 Gain State	1																		
AEM Multiplexer 1 BAND 3 Gain State	2																		
AEM Multiplexer 1 BAND 4 Gain State	3																		
AEM Multiplexer 1 BAND 5 Gain State	4																		
AEM Multiplexer 1 BAND 6 PRI Gain State	5																		
AEM Multiplexer 1 BAND 7 Gain State	6																		
AEM Multiplexer 1 BAND P Gain State	7																		
83	<table border="0"> <tr> <td>Serial Word "K"</td> <td>Bit</td> </tr> <tr> <td>AEM Multiplexer 2 BAND 1 Gain State</td> <td>0</td> </tr> <tr> <td>AEM Multiplexer 2 BAND 2 Gain State</td> <td>1</td> </tr> <tr> <td>AEM Multiplexer 2 BAND 3 Gain State</td> <td>2</td> </tr> <tr> <td>AEM Multiplexer 2 BAND 4 Gain State</td> <td>3</td> </tr> <tr> <td>AEM Multiplexer 2 BAND 5 Gain State</td> <td>4</td> </tr> <tr> <td>AEM Multiplexer 2 BAND 6 PRI Gain State</td> <td>5</td> </tr> <tr> <td>AEM Multiplexer 2 BAND 7 Gain State</td> <td>6</td> </tr> <tr> <td>AEM Multiplexer 2 BAND P Gain State</td> <td>7</td> </tr> </table>	Serial Word "K"	Bit	AEM Multiplexer 2 BAND 1 Gain State	0	AEM Multiplexer 2 BAND 2 Gain State	1	AEM Multiplexer 2 BAND 3 Gain State	2	AEM Multiplexer 2 BAND 4 Gain State	3	AEM Multiplexer 2 BAND 5 Gain State	4	AEM Multiplexer 2 BAND 6 PRI Gain State	5	AEM Multiplexer 2 BAND 7 Gain State	6	AEM Multiplexer 2 BAND P Gain State	7
Serial Word "K"	Bit																		
AEM Multiplexer 2 BAND 1 Gain State	0																		
AEM Multiplexer 2 BAND 2 Gain State	1																		
AEM Multiplexer 2 BAND 3 Gain State	2																		
AEM Multiplexer 2 BAND 4 Gain State	3																		
AEM Multiplexer 2 BAND 5 Gain State	4																		
AEM Multiplexer 2 BAND 6 PRI Gain State	5																		
AEM Multiplexer 2 BAND 7 Gain State	6																		
AEM Multiplexer 2 BAND P Gain State	7																		
84-95	Zero Fill																		
96	00000001																		
97	00000001																		
98	00000001																		
99	00000001																		
100	00000001																		
101	00000001																		
102	00000001																		
103	00000001																		
104-107	Zero Fill																		
108	Bits 0-3 = 0000 ; Bits 4-7 = ADS-X Temp1																		
109	ADS-X Temp 1																		
110	Bits 0-3 = 0000 ; Bits 4-7 = ADS -Y Temp2																		

TABLE 18. ETM+ PCD MAJOR FRAME (1) WORD 72 (CONT)

MINOR FRAME	DESCRIPTION
111	ADS-Y Temp 2
112	Bits 0-3 = 0000 ; Bits 4-7 = ADS-z Temp 3
113	ADS-Z Temp 3
114	Bits 0-3 = 0000 ; Bits 4-7 = A/D Temp - ADS Electronics
115	A/D Temp - ADS Electronics
116-117	A/D Ground Reference
118-127	Zero Fill

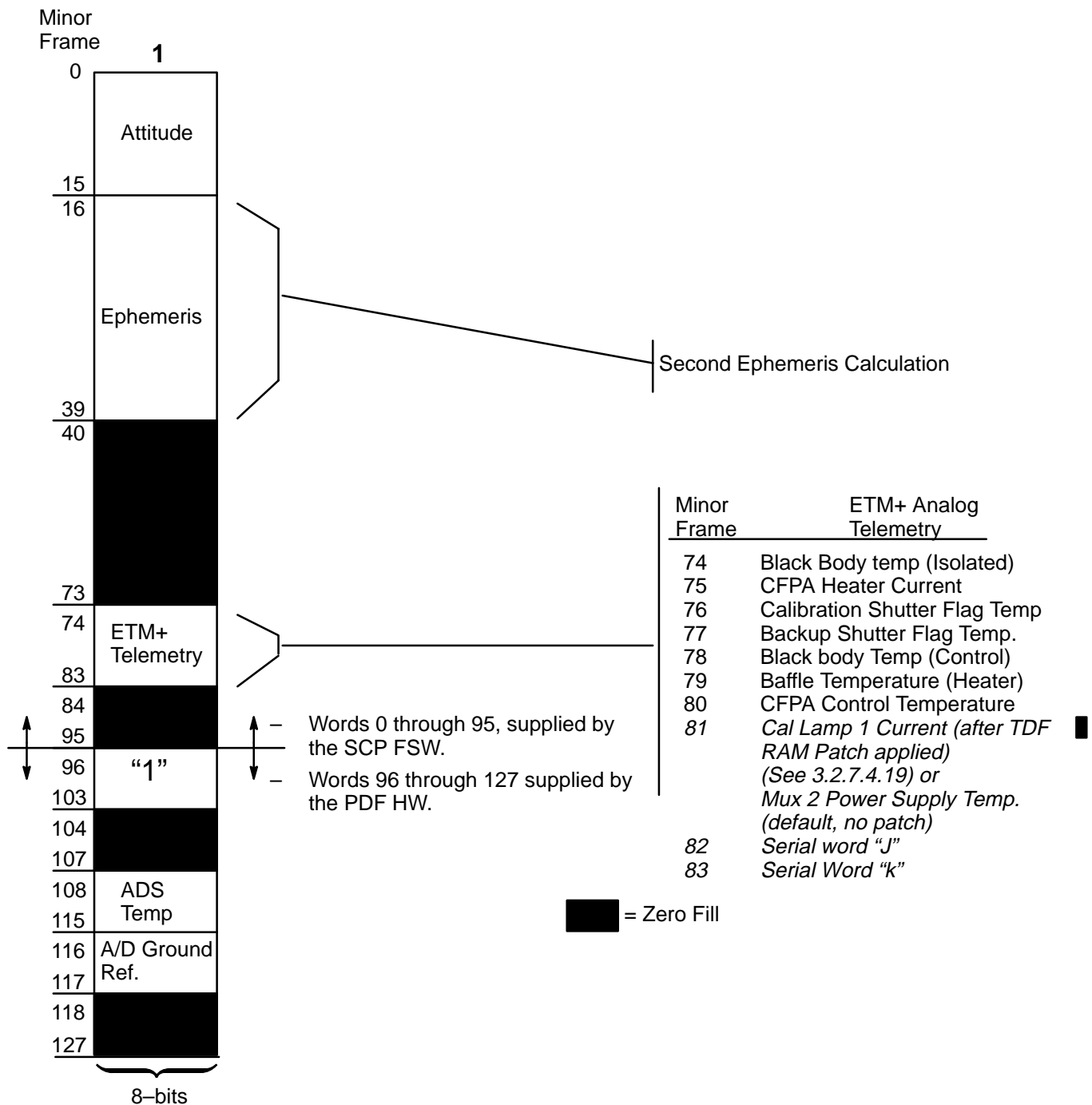

Figure 26. PCD Subcommutation Major Frame (1) Word 72

TABLE 19. ETM+ PCD MAJOR FRAME (2) WORD 72

MINOR FRAME	DESCRIPTION																		
0	Euler Parameter 1 (EPA 1)																		
1	Euler Parameter 1 (EPA 1)																		
2	Euler Parameter 1 (EPA 1)																		
3	Euler Parameter 1 (EPA 1)																		
4	Euler Parameter 2 (EPA 2)																		
5	Euler Parameter 2 (EPA 2)																		
6	Euler Parameter 2 (EPA 2)																		
7	Euler Parameter 2 (EPA 2)																		
8	Euler Parameter 3 (EPA 3)																		
9	Euler Parameter 3 (EPA 3)																		
10	Euler Parameter 3 (EPA 3)																		
11	Euler Parameter 3 (EPA 3)																		
12	Euler Parameter 4 (EPA 4)																		
13	Euler Parameter 4 (EPA 4)																		
14	Euler Parameter 4 (EPA 4)																		
15	Euler Parameter 4 (EPA 4)																		
16	MEM Heat Sink Power Supply #2																		
17	Silicon Focal-Plane Assembly Temp.																		
18	Zero Fill																		
19	Baffle Temperature (Tube)																		
20	MEM Heat Sink Power Supply #1																		
21	Cold FPA Monitor Temperature																		
22	Baffle Temperature (Support)																		
23	Calibration Lamp Housing Temperature																		
24	Scan-Line Corrector Temperature																		
25	Calibration Shutter Hub Temperature																		
26	Ambient Preamp Temperature (High Channels)																		
27	Band 4 Post Amp Temperature																		
28	Spare Zero Fill																		
29	Band 7 Preamp Temperature																		
30	Ambient Preamp Temperature (Low Channels)																		
31	<table border="0"> <tr> <td>Serial Word "A"</td> <td>Bits</td> </tr> <tr> <td>PS 2 Thermal Shutdown Enabled</td> <td>0</td> </tr> <tr> <td>PS 1 Thermal Shutdown Enabled</td> <td>1</td> </tr> <tr> <td>SMA +Z Heater Controller ON</td> <td>2</td> </tr> <tr> <td>SMA -Z Heater Controller ON</td> <td>3</td> </tr> <tr> <td>Spare</td> <td>4</td> </tr> <tr> <td>Shutter Fusible Link Switch A Closed</td> <td>5</td> </tr> <tr> <td>Shutter Fusible Link Switch B Closed</td> <td>6</td> </tr> <tr> <td>Shutter Fusible Link Switch C Closed</td> <td>7</td> </tr> </table>	Serial Word "A"	Bits	PS 2 Thermal Shutdown Enabled	0	PS 1 Thermal Shutdown Enabled	1	SMA +Z Heater Controller ON	2	SMA -Z Heater Controller ON	3	Spare	4	Shutter Fusible Link Switch A Closed	5	Shutter Fusible Link Switch B Closed	6	Shutter Fusible Link Switch C Closed	7
Serial Word "A"	Bits																		
PS 2 Thermal Shutdown Enabled	0																		
PS 1 Thermal Shutdown Enabled	1																		
SMA +Z Heater Controller ON	2																		
SMA -Z Heater Controller ON	3																		
Spare	4																		
Shutter Fusible Link Switch A Closed	5																		
Shutter Fusible Link Switch B Closed	6																		
Shutter Fusible Link Switch C Closed	7																		

TABLE 19. ETM+ PCD MAJOR FRAME (2) WORD 72 (CONT)

MINOR FRAME	DESCRIPTION																		
32	<table border="0"> <tr> <td>Serial Word "B"</td> <td style="text-align: right;">Bits</td> </tr> <tr> <td>Band 1 ON</td> <td style="text-align: right;">0</td> </tr> <tr> <td>Band 2 ON</td> <td style="text-align: right;">1</td> </tr> <tr> <td>Band 3 ON</td> <td style="text-align: right;">2</td> </tr> <tr> <td>Band 4 ON</td> <td style="text-align: right;">3</td> </tr> <tr> <td>Band 5 ON</td> <td style="text-align: right;">4</td> </tr> <tr> <td>Band 6/MIR ON</td> <td style="text-align: right;">5</td> </tr> <tr> <td>Band 7 ON</td> <td style="text-align: right;">6</td> </tr> <tr> <td>Cold Stage Telemetry ON</td> <td style="text-align: right;">7</td> </tr> </table>	Serial Word "B"	Bits	Band 1 ON	0	Band 2 ON	1	Band 3 ON	2	Band 4 ON	3	Band 5 ON	4	Band 6/MIR ON	5	Band 7 ON	6	Cold Stage Telemetry ON	7
Serial Word "B"	Bits																		
Band 1 ON	0																		
Band 2 ON	1																		
Band 3 ON	2																		
Band 4 ON	3																		
Band 5 ON	4																		
Band 6/MIR ON	5																		
Band 7 ON	6																		
Cold Stage Telemetry ON	7																		
33	<table border="0"> <tr> <td>Serial Word "C"</td> <td style="text-align: right;">Bits</td> </tr> <tr> <td>Cooler Door Closed</td> <td style="text-align: right;">0</td> </tr> <tr> <td>Cooler Door Outgas Position</td> <td style="text-align: right;">1</td> </tr> <tr> <td>Cooler Door Full Open</td> <td style="text-align: right;">2</td> </tr> <tr> <td>Cooler Door Magnet ON</td> <td style="text-align: right;">3</td> </tr> <tr> <td>Cooler Door Motor Drive ON</td> <td style="text-align: right;">4</td> </tr> <tr> <td>Cooler Door Fusible Link Switch A Closed</td> <td style="text-align: right;">5</td> </tr> <tr> <td>Cooler Door Fusible Link Switch B Closed</td> <td style="text-align: right;">6</td> </tr> <tr> <td>Cooler Door Fusible Link Switch C Closed</td> <td style="text-align: right;">7</td> </tr> </table>	Serial Word "C"	Bits	Cooler Door Closed	0	Cooler Door Outgas Position	1	Cooler Door Full Open	2	Cooler Door Magnet ON	3	Cooler Door Motor Drive ON	4	Cooler Door Fusible Link Switch A Closed	5	Cooler Door Fusible Link Switch B Closed	6	Cooler Door Fusible Link Switch C Closed	7
Serial Word "C"	Bits																		
Cooler Door Closed	0																		
Cooler Door Outgas Position	1																		
Cooler Door Full Open	2																		
Cooler Door Magnet ON	3																		
Cooler Door Motor Drive ON	4																		
Cooler Door Fusible Link Switch A Closed	5																		
Cooler Door Fusible Link Switch B Closed	6																		
Cooler Door Fusible Link Switch C Closed	7																		
34	<table border="0"> <tr> <td>Serial Word "D"</td> <td style="text-align: right;">Bits</td> </tr> <tr> <td>Calibration Lamp 1 ON</td> <td style="text-align: right;">0</td> </tr> <tr> <td>Calibration Lamp 2 ON</td> <td style="text-align: right;">1</td> </tr> <tr> <td>Spare</td> <td style="text-align: right;">2</td> </tr> <tr> <td>Calibration Lamp 1 Backup ON</td> <td style="text-align: right;">3</td> </tr> <tr> <td>Calibration Lamp 2 Backup ON</td> <td style="text-align: right;">4</td> </tr> <tr> <td>Spare</td> <td style="text-align: right;">5</td> </tr> <tr> <td>Spare</td> <td style="text-align: right;">6</td> </tr> <tr> <td>Spare</td> <td style="text-align: right;">7</td> </tr> </table>	Serial Word "D"	Bits	Calibration Lamp 1 ON	0	Calibration Lamp 2 ON	1	Spare	2	Calibration Lamp 1 Backup ON	3	Calibration Lamp 2 Backup ON	4	Spare	5	Spare	6	Spare	7
Serial Word "D"	Bits																		
Calibration Lamp 1 ON	0																		
Calibration Lamp 2 ON	1																		
Spare	2																		
Calibration Lamp 1 Backup ON	3																		
Calibration Lamp 2 Backup ON	4																		
Spare	5																		
Spare	6																		
Spare	7																		
35	<table border="0"> <tr> <td>Serial Word "E"</td> <td style="text-align: right;">Bits</td> </tr> <tr> <td>Band P ON</td> <td style="text-align: right;">0</td> </tr> <tr> <td>Spare</td> <td style="text-align: right;">1</td> </tr> <tr> <td>Blackbody Heater Controller ON</td> <td style="text-align: right;">2</td> </tr> <tr> <td>Blackbody T2 ON</td> <td style="text-align: right;">3</td> </tr> <tr> <td>Blackbody T3 ON</td> <td style="text-align: right;">4</td> </tr> <tr> <td>Blackbody Backup ON</td> <td style="text-align: right;">5</td> </tr> <tr> <td>SME 1 ON</td> <td style="text-align: right;">6</td> </tr> <tr> <td>SME 2 ON</td> <td style="text-align: right;">7</td> </tr> </table>	Serial Word "E"	Bits	Band P ON	0	Spare	1	Blackbody Heater Controller ON	2	Blackbody T2 ON	3	Blackbody T3 ON	4	Blackbody Backup ON	5	SME 1 ON	6	SME 2 ON	7
Serial Word "E"	Bits																		
Band P ON	0																		
Spare	1																		
Blackbody Heater Controller ON	2																		
Blackbody T2 ON	3																		
Blackbody T3 ON	4																		
Blackbody Backup ON	5																		
SME 1 ON	6																		
SME 2 ON	7																		
36	<table border="0"> <tr> <td>Serial Word "F"</td> <td style="text-align: right;">Bits</td> </tr> <tr> <td>Baffle Heater Controller ON</td> <td style="text-align: right;">0</td> </tr> <tr> <td>Baffle Heater Backup ON</td> <td style="text-align: right;">1</td> </tr> <tr> <td>Spare</td> <td style="text-align: right;">2</td> </tr> <tr> <td>Spare</td> <td style="text-align: right;">3</td> </tr> <tr> <td>Spare</td> <td style="text-align: right;">4</td> </tr> <tr> <td>Spare</td> <td style="text-align: right;">5</td> </tr> <tr> <td>Spare</td> <td style="text-align: right;">6</td> </tr> <tr> <td>Spare</td> <td style="text-align: right;">7</td> </tr> </table>	Serial Word "F"	Bits	Baffle Heater Controller ON	0	Baffle Heater Backup ON	1	Spare	2	Spare	3	Spare	4	Spare	5	Spare	6	Spare	7
Serial Word "F"	Bits																		
Baffle Heater Controller ON	0																		
Baffle Heater Backup ON	1																		
Spare	2																		
Spare	3																		
Spare	4																		
Spare	5																		
Spare	6																		
Spare	7																		
37	<table border="0"> <tr> <td>Serial Word "G"</td> <td style="text-align: right;">Bits</td> </tr> <tr> <td>Scan Line Corrector 1 ON</td> <td style="text-align: right;">0</td> </tr> <tr> <td>Scan Line Corrector 2 ON</td> <td style="text-align: right;">1</td> </tr> <tr> <td>Calibration Shutter ON</td> <td style="text-align: right;">2</td> </tr> <tr> <td>Calibration Shutter Phase Error</td> <td style="text-align: right;">3</td> </tr> <tr> <td>Calibration Shutter Amplitude Error</td> <td style="text-align: right;">4</td> </tr> <tr> <td>Backup Shutter ON</td> <td style="text-align: right;">5</td> </tr> <tr> <td>Backup Shutter Phase Error</td> <td style="text-align: right;">6</td> </tr> <tr> <td>Backup Shutter Amplitude Error</td> <td style="text-align: right;">7</td> </tr> </table>	Serial Word "G"	Bits	Scan Line Corrector 1 ON	0	Scan Line Corrector 2 ON	1	Calibration Shutter ON	2	Calibration Shutter Phase Error	3	Calibration Shutter Amplitude Error	4	Backup Shutter ON	5	Backup Shutter Phase Error	6	Backup Shutter Amplitude Error	7
Serial Word "G"	Bits																		
Scan Line Corrector 1 ON	0																		
Scan Line Corrector 2 ON	1																		
Calibration Shutter ON	2																		
Calibration Shutter Phase Error	3																		
Calibration Shutter Amplitude Error	4																		
Backup Shutter ON	5																		
Backup Shutter Phase Error	6																		
Backup Shutter Amplitude Error	7																		

TABLE 19. ETM+ PCD MAJOR FRAME (2) WORD 72 (CONT)

MINOR FRAME	DESCRIPTION																		
38	<table border="0"> <tr> <td>Serial Word "H"</td> <td style="text-align: right;">Bits</td> </tr> <tr> <td>Cold Stage Heater Controller ON</td> <td style="text-align: right;">0</td> </tr> <tr> <td>Cold Stage Outgas Heater Enabled</td> <td style="text-align: right;">1</td> </tr> <tr> <td>Intermediate Stage Heater Controller ON</td> <td style="text-align: right;">2</td> </tr> <tr> <td>Intermediate Stage Heater Enabled</td> <td style="text-align: right;">3</td> </tr> <tr> <td>CFPA Heater Controller ON</td> <td style="text-align: right;">4</td> </tr> <tr> <td>CFPA T2 Relay ON</td> <td style="text-align: right;">5</td> </tr> <tr> <td>CFPA T3 Relay ON</td> <td style="text-align: right;">6</td> </tr> <tr> <td>CFPA Telemetry ON</td> <td style="text-align: right;">7</td> </tr> </table>	Serial Word "H"	Bits	Cold Stage Heater Controller ON	0	Cold Stage Outgas Heater Enabled	1	Intermediate Stage Heater Controller ON	2	Intermediate Stage Heater Enabled	3	CFPA Heater Controller ON	4	CFPA T2 Relay ON	5	CFPA T3 Relay ON	6	CFPA Telemetry ON	7
Serial Word "H"	Bits																		
Cold Stage Heater Controller ON	0																		
Cold Stage Outgas Heater Enabled	1																		
Intermediate Stage Heater Controller ON	2																		
Intermediate Stage Heater Enabled	3																		
CFPA Heater Controller ON	4																		
CFPA T2 Relay ON	5																		
CFPA T3 Relay ON	6																		
CFPA Telemetry ON	7																		
39	<table border="0"> <tr> <td>Serial Word "I"</td> <td style="text-align: right;">Bits</td> </tr> <tr> <td>DC Restore Normal</td> <td style="text-align: right;">0</td> </tr> <tr> <td>Frame DC Restore Selected</td> <td style="text-align: right;">1</td> </tr> <tr> <td>Telemetry Scaling ON</td> <td style="text-align: right;">2</td> </tr> <tr> <td>SMA +Z Heater Enabled</td> <td style="text-align: right;">3</td> </tr> <tr> <td>SMA -Z Heater Enabled</td> <td style="text-align: right;">4</td> </tr> <tr> <td>Spare</td> <td style="text-align: right;">5</td> </tr> <tr> <td>SME 1 Select SAM</td> <td style="text-align: right;">6</td> </tr> <tr> <td>Spare Opto</td> <td style="text-align: right;">7</td> </tr> </table>	Serial Word "I"	Bits	DC Restore Normal	0	Frame DC Restore Selected	1	Telemetry Scaling ON	2	SMA +Z Heater Enabled	3	SMA -Z Heater Enabled	4	Spare	5	SME 1 Select SAM	6	Spare Opto	7
Serial Word "I"	Bits																		
DC Restore Normal	0																		
Frame DC Restore Selected	1																		
Telemetry Scaling ON	2																		
SMA +Z Heater Enabled	3																		
SMA -Z Heater Enabled	4																		
Spare	5																		
SME 1 Select SAM	6																		
Spare Opto	7																		
40	Primary Mirror Temperature																		
41	Primary Mirror Mask Temperature																		
42	Secondary Mirror Temperature																		
43	Secondary Mirror Mask Temperature																		
44	Telescope Housing Temperature																		
45	Telescope Baseplate Temperature																		
46	Pan Band Post Amplifier Temperature																		
47-49	Zero Fill																		
50	X-Position																		
51	X-Position																		
52	X-Position																		
53	X-Position																		
54	Y-Position																		
55	Y-Position																		
56	Y-Position																		
57	Y-Position																		
58	Z-Position																		
59	Z-Position																		
60	Z-Position																		
61	Z-Position																		
62	X-Velocity																		
63	X-Velocity																		
64	X-Velocity																		
65	X-Velocity																		
66	Y-Velocity																		
67	Y-Velocity																		

TABLE 19. ETM+ PCDMAJOR FRAME (2) WORD 72 (CONT)

MINOR FRAME	DESCRIPTION																		
68	Y-Velocity																		
69	Y-Velocity																		
70	Z-Velocity																		
71	Z-Velocity																		
72	Z-Velocity																		
73	Z-Velocity																		
74	Black body Temperature (Isolated)																		
75	CFPA Heater Current																		
76	Calibration Shutter Flag Temperature																		
77	Backup Shutter Flag Temperature																		
78	Black Body Temperature (Control)																		
79	Baffle Temperature (Heater)																		
80	CFPA Control Temperature																		
81	<table border="0"> <tr> <td>Serial Word "L"</td> <td>Bit</td> </tr> <tr> <td>Cooler Door Direction (1=Open)</td> <td>0</td> </tr> <tr> <td>Cooler Door Move Enable</td> <td>1</td> </tr> <tr> <td>FAC Failsafe Static Motor Power ON</td> <td>2</td> </tr> <tr> <td>FAC Primary Static Motor Power ON</td> <td>3</td> </tr> <tr> <td>FAC Primary Motor Power ON</td> <td>4</td> </tr> <tr> <td>FAC Failsafe Motor Power ON</td> <td>5</td> </tr> <tr> <td>FAC Primary Controller Direction</td> <td>6</td> </tr> <tr> <td>FAC Failsafe Controller Direction</td> <td>7</td> </tr> </table>	Serial Word "L"	Bit	Cooler Door Direction (1=Open)	0	Cooler Door Move Enable	1	FAC Failsafe Static Motor Power ON	2	FAC Primary Static Motor Power ON	3	FAC Primary Motor Power ON	4	FAC Failsafe Motor Power ON	5	FAC Primary Controller Direction	6	FAC Failsafe Controller Direction	7
Serial Word "L"	Bit																		
Cooler Door Direction (1=Open)	0																		
Cooler Door Move Enable	1																		
FAC Failsafe Static Motor Power ON	2																		
FAC Primary Static Motor Power ON	3																		
FAC Primary Motor Power ON	4																		
FAC Failsafe Motor Power ON	5																		
FAC Primary Controller Direction	6																		
FAC Failsafe Controller Direction	7																		
82	<table border="0"> <tr> <td>Serial Word "M"</td> <td>Bit</td> </tr> <tr> <td>Mux 1/2 Analog Power Selected</td> <td>0</td> </tr> <tr> <td>Mux 1/2 Digital Power Selected</td> <td>1</td> </tr> <tr> <td>Spare</td> <td>2</td> </tr> <tr> <td>Spare</td> <td>3</td> </tr> <tr> <td>FAC Primary Controller Single-Step Sizes</td> <td>4</td> </tr> <tr> <td>FAC Failsafe Controller single-Step Sizes</td> <td>5</td> </tr> <tr> <td>FAC Primary Controller Power ON</td> <td>6</td> </tr> <tr> <td>FAC Failsafe Controller Power ON</td> <td>7</td> </tr> </table>	Serial Word "M"	Bit	Mux 1/2 Analog Power Selected	0	Mux 1/2 Digital Power Selected	1	Spare	2	Spare	3	FAC Primary Controller Single-Step Sizes	4	FAC Failsafe Controller single-Step Sizes	5	FAC Primary Controller Power ON	6	FAC Failsafe Controller Power ON	7
Serial Word "M"	Bit																		
Mux 1/2 Analog Power Selected	0																		
Mux 1/2 Digital Power Selected	1																		
Spare	2																		
Spare	3																		
FAC Primary Controller Single-Step Sizes	4																		
FAC Failsafe Controller single-Step Sizes	5																		
FAC Primary Controller Power ON	6																		
FAC Failsafe Controller Power ON	7																		
83	<table border="0"> <tr> <td>Serial Word "N"</td> <td>Bits</td> </tr> <tr> <td>AEM Multiplexer 1 ON</td> <td>0</td> </tr> <tr> <td>AEM Multiplexer 2 ON</td> <td>1</td> </tr> <tr> <td>AEM Multiplexer 1 MDE ON Status</td> <td>2</td> </tr> <tr> <td>AEM Multiplexer 2 MDE ON Status</td> <td>3</td> </tr> <tr> <td>AEM Multiplexer 1 Band 6 RDT Gain State</td> <td>4</td> </tr> <tr> <td>AEM Multiplexer 2 Band 6 RDT Gain State</td> <td>5</td> </tr> <tr> <td>AEM Multiplexer 1 Data Priority Selected</td> <td>6</td> </tr> <tr> <td>AEM Multiplexer 2 Data Priority Selected</td> <td>7</td> </tr> </table>	Serial Word "N"	Bits	AEM Multiplexer 1 ON	0	AEM Multiplexer 2 ON	1	AEM Multiplexer 1 MDE ON Status	2	AEM Multiplexer 2 MDE ON Status	3	AEM Multiplexer 1 Band 6 RDT Gain State	4	AEM Multiplexer 2 Band 6 RDT Gain State	5	AEM Multiplexer 1 Data Priority Selected	6	AEM Multiplexer 2 Data Priority Selected	7
Serial Word "N"	Bits																		
AEM Multiplexer 1 ON	0																		
AEM Multiplexer 2 ON	1																		
AEM Multiplexer 1 MDE ON Status	2																		
AEM Multiplexer 2 MDE ON Status	3																		
AEM Multiplexer 1 Band 6 RDT Gain State	4																		
AEM Multiplexer 2 Band 6 RDT Gain State	5																		
AEM Multiplexer 1 Data Priority Selected	6																		
AEM Multiplexer 2 Data Priority Selected	7																		
84	<table border="0"> <tr> <td>Serial Word "P"</td> <td>Bit</td> </tr> <tr> <td>FAC Stow Position Switch PRI</td> <td>0</td> </tr> <tr> <td>FAC Stow Position Switch RDT</td> <td>1</td> </tr> <tr> <td>FAC Calibration Position Switch PRI</td> <td>2</td> </tr> <tr> <td>FAC Calibration Position Switch RDT</td> <td>3</td> </tr> <tr> <td>FAC Calibration/Stow Move ON Status PRI</td> <td>4</td> </tr> <tr> <td>FAC Calibration/Stow Move ON Status RDT</td> <td>5</td> </tr> <tr> <td>FAC Single-Step Move ON Status PRI</td> <td>6</td> </tr> <tr> <td>FAC Single-Step Move ON Status RDT</td> <td>7</td> </tr> </table>	Serial Word "P"	Bit	FAC Stow Position Switch PRI	0	FAC Stow Position Switch RDT	1	FAC Calibration Position Switch PRI	2	FAC Calibration Position Switch RDT	3	FAC Calibration/Stow Move ON Status PRI	4	FAC Calibration/Stow Move ON Status RDT	5	FAC Single-Step Move ON Status PRI	6	FAC Single-Step Move ON Status RDT	7
Serial Word "P"	Bit																		
FAC Stow Position Switch PRI	0																		
FAC Stow Position Switch RDT	1																		
FAC Calibration Position Switch PRI	2																		
FAC Calibration Position Switch RDT	3																		
FAC Calibration/Stow Move ON Status PRI	4																		
FAC Calibration/Stow Move ON Status RDT	5																		
FAC Single-Step Move ON Status PRI	6																		
FAC Single-Step Move ON Status RDT	7																		
85-95	Zero Fill																		
96	000010																		

TABLE 19. ETM+ PCDMAJOR FRAME (2) WORD 72 (CONT)

MINOR FRAME	DESCRIPTION
97	0000010
98	0000010
99	0000010
100	0000010
101	0000010
102	0000010
103	0000010
104-107	Zero Fill
108	Bits 0-3 = 0000 ; Bits 4-7 = ADS-X Temp 1
109	ADS Temp 1
110	Bits 0-3 = 0000 ; Bits 4-7 = ADS-Y Temp 2
111	Ads-Y Temp 2
112	Bits 0-3 = 0000; Bits 4-7 = ADS-Z Temp 3
113	ADS-Z Temp 3
114	Bits 0-3 = 0000 ; Bits 4-7 = A/D Temp - ADS Electronics
115	A/D Temp - ADS Electronics
116-117	A/D Ground Reference
118-127	Zero Fill

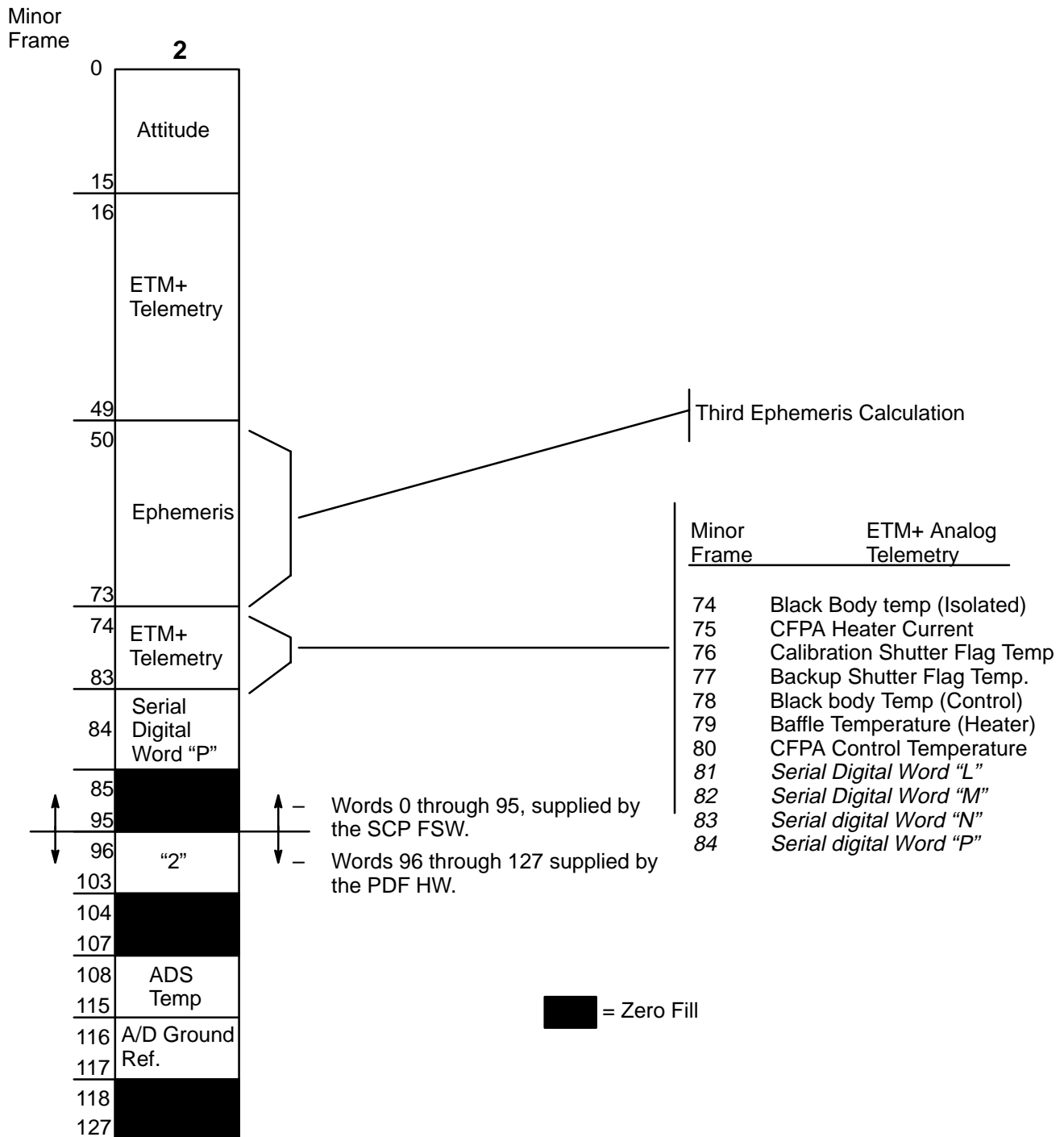

Figure 27. PCD Subcommutation Major Frame (2) Word 72

TABLE 20. ETM+ PCD MAJOR FRAME (3) WORD 72

MINOR FRAME	DESCRIPTION
0	Euler Parameter 1 (EPA 1)
1	Euler Parameter 1 (EPA 1)
2	Euler Parameter 1 (EPA 1)
3	Euler Parameter 1 (EPA 1)
4	Euler Parameter 2 (EPA 2)
5	Euler Parameter 2 (EPA 2)
6	Euler Parameter 2 (EPA 2)
7	Euler Parameter 2 (EPA 2)
8	Euler Parameter 3 (EPA 3)
9	Euler Parameter 3 (EPA 3)
10	Euler Parameter 3 (EPA 3)
11	Euler Parameter 3 (EPA 3)
12	Euler Parameter 4 (EPA 4)
13	Euler Parameter 4 (EPA 4)
14	Euler Parameter 4 (EPA 4)
15	Euler Parameter 4 (EPA 4)
16	X-Position
17	X-Position
18	X-Position
19	X-Position
20	Y-Position
21	Y-Position
22	Y-Position
23	Y-Position
24	Z-Position
25	Z-Position
26	Z-Position
27	Z-Position
28	X-Velocity
29	X-Velocity
30	X-Velocity
31	X-Velocity
32	Y-Velocity
33	Y-Velocity
34	Y-Velocity
35	Y-Velocity
36	Z-Velocity

TABLE 20. ETM+ PCD MAJOR FRAME (3) WORD 72 (CONT)

MINOR FRAME	DESCRIPTION																		
37	Z-Velocity																		
38	Z-Velocity																		
39	Z-Velocity																		
40-73	Zero Fill																		
74	Black Body Temperature (Isolated)																		
75	CFPA Heater Current																		
76	Calibration Shutter Flag																		
77	Backup Shutter Flag Temperature																		
78	Black Body temperature (Control)																		
79	Baffle Temperature																		
80	CFPA Control Temperature																		
81	<table border="0"> <tr> <td>Serial Word "Q"</td> <td>Bits</td> </tr> <tr> <td>FAC Pull-Pin Heater 1 ON</td> <td>0</td> </tr> <tr> <td>FAC Pull-Pin Heater 2 ON</td> <td>1</td> </tr> <tr> <td>FAC Pull-Pin Heater Power, Enable PRI</td> <td>2</td> </tr> <tr> <td>FAC Pull-Pin Heater Power</td> <td>3</td> </tr> <tr> <td>FAC Pull-Pin Retracted Position Switch PRI</td> <td>4</td> </tr> <tr> <td>FAC Pull-Pin Retracted Position Switch RDT</td> <td>5</td> </tr> <tr> <td>FAC Pull-Pin Fully Retracted Position Switch PRI</td> <td>6</td> </tr> <tr> <td>FAC Pull-Pin Fully Retracted Position Switch RDT</td> <td>7</td> </tr> </table>	Serial Word "Q"	Bits	FAC Pull-Pin Heater 1 ON	0	FAC Pull-Pin Heater 2 ON	1	FAC Pull-Pin Heater Power, Enable PRI	2	FAC Pull-Pin Heater Power	3	FAC Pull-Pin Retracted Position Switch PRI	4	FAC Pull-Pin Retracted Position Switch RDT	5	FAC Pull-Pin Fully Retracted Position Switch PRI	6	FAC Pull-Pin Fully Retracted Position Switch RDT	7
Serial Word "Q"	Bits																		
FAC Pull-Pin Heater 1 ON	0																		
FAC Pull-Pin Heater 2 ON	1																		
FAC Pull-Pin Heater Power, Enable PRI	2																		
FAC Pull-Pin Heater Power	3																		
FAC Pull-Pin Retracted Position Switch PRI	4																		
FAC Pull-Pin Retracted Position Switch RDT	5																		
FAC Pull-Pin Fully Retracted Position Switch PRI	6																		
FAC Pull-Pin Fully Retracted Position Switch RDT	7																		
82	<table border="0"> <tr> <td>Serial Word "R":</td> <td>Bits</td> </tr> <tr> <td>FAC Primary CW Rotation Switch Status</td> <td>0</td> </tr> <tr> <td>FAC Primary CCW Rotation Switch Status</td> <td>1</td> </tr> <tr> <td>FAC Redundant CW Rotation Switch Status</td> <td>2</td> </tr> <tr> <td>FAC Redundant CCW Rotation Switch Status</td> <td>3</td> </tr> <tr> <td>Spare</td> <td>4</td> </tr> <tr> <td>Spare</td> <td>5</td> </tr> <tr> <td>Spare</td> <td>6</td> </tr> <tr> <td>Spare</td> <td>7</td> </tr> </table>	Serial Word "R":	Bits	FAC Primary CW Rotation Switch Status	0	FAC Primary CCW Rotation Switch Status	1	FAC Redundant CW Rotation Switch Status	2	FAC Redundant CCW Rotation Switch Status	3	Spare	4	Spare	5	Spare	6	Spare	7
Serial Word "R":	Bits																		
FAC Primary CW Rotation Switch Status	0																		
FAC Primary CCW Rotation Switch Status	1																		
FAC Redundant CW Rotation Switch Status	2																		
FAC Redundant CCW Rotation Switch Status	3																		
Spare	4																		
Spare	5																		
Spare	6																		
Spare	7																		
83	<table border="0"> <tr> <td>Serial Word "S"</td> <td>Bits</td> </tr> <tr> <td>Command Reject, Enable 1 P</td> <td>0</td> </tr> <tr> <td>Command Reject, Enable 2 P</td> <td>1</td> </tr> <tr> <td>Command Reject, Enable 3 P</td> <td>2</td> </tr> <tr> <td>Command Reject, Enable 4 P</td> <td>3</td> </tr> <tr> <td>Command Reject, Enable 1 R</td> <td>4</td> </tr> <tr> <td>Command Reject, Enable 2 R</td> <td>5</td> </tr> <tr> <td>Command Reject, Enable 3 R</td> <td>6</td> </tr> <tr> <td>Command Reject, Enable 4 R</td> <td>7</td> </tr> </table>	Serial Word "S"	Bits	Command Reject, Enable 1 P	0	Command Reject, Enable 2 P	1	Command Reject, Enable 3 P	2	Command Reject, Enable 4 P	3	Command Reject, Enable 1 R	4	Command Reject, Enable 2 R	5	Command Reject, Enable 3 R	6	Command Reject, Enable 4 R	7
Serial Word "S"	Bits																		
Command Reject, Enable 1 P	0																		
Command Reject, Enable 2 P	1																		
Command Reject, Enable 3 P	2																		
Command Reject, Enable 4 P	3																		
Command Reject, Enable 1 R	4																		
Command Reject, Enable 2 R	5																		
Command Reject, Enable 3 R	6																		
Command Reject, Enable 4 R	7																		
84	Spacecraft CPUMODE																		
85-95	Zero Fill																		
96	0000011																		
97	0000011																		
98	0000011																		

TABLE 20. ETM+ PCD MAJOR FRAME (3) WORD 72 (CONT)

MINOR FRAME	DESCRIPTION
99	00000011
100	00000011
101	00000011
102	00000011
103	00000011
104-107	Zero Fill
108	Bits 0-3 = 0000 ; Bits 4-7 = ADS-X Temp 1
109	ADS-X Temp 1
110	Bits 0-3 = 0000 ; Bits 4-7 = ADS-Y Temp 2
111	ADS-Y Temp 2
112	Bits 0-3 = 0000 ; Bits 4-7 = ADS-Z Temp 3
113	ADS-Z Temp 3
114	Bits 0-3 = 0000 ; Bits 4-7 = A/D Temp - ADS Electronics
115	A/D Temp - ADS Electronics
116-117	A/D Ground Reference
118-127	Zero Fill

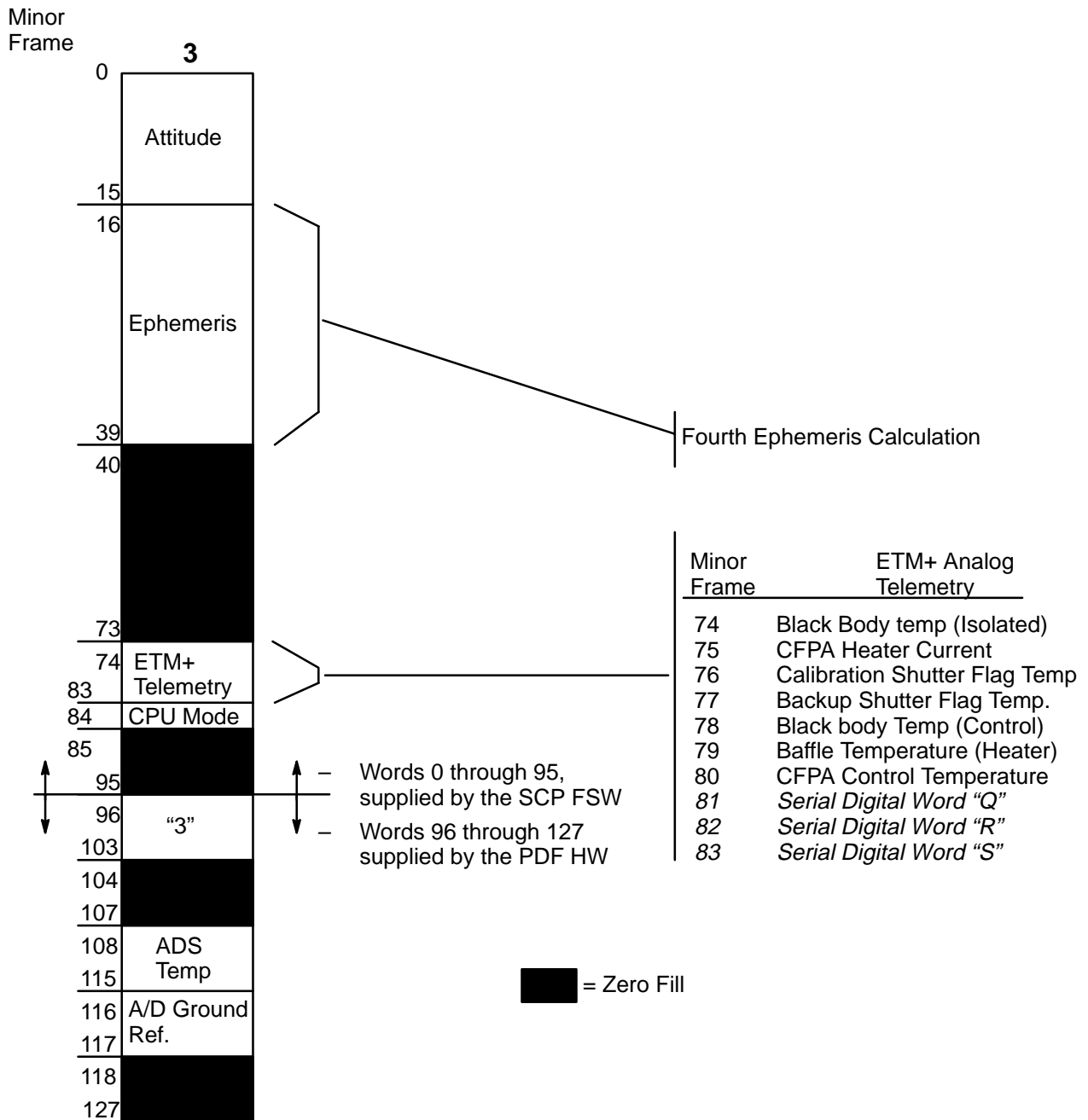

Figure 28. PCD Subcommutation Major Frame (3) Word 72

3.3 SOLID STATE RECORDER

3.3.1 FUNCTIONAL ARCHITECTURE

Figure 29 shows the functional architecture and relationship between the ETM+ instrument, the Solid State Recorder (SSR), and the X-band communication links. ETM+ wideband data is collected by the ETM+ sensors and CCSDS-encoded by formatters internal to the ETM+. The CCSDS-formatted data is transmitted by the ETM+, in two 75 Mbps bitstreams, to the Baseband Switching Unit (BSU) for immediate transmission via an X-band link and/or for recording on the SSR. The two 75 Mbps ETM+ bitstreams remain a matched pair throughout record, playback and transmission operations. The wideband data is recorded at an aggregate rate of 150 Mbps. For transmission of recorded wideband data, the recorded data is played back from the recorder using one or two 150 Mbps bitstreams and sent to the X-band modulator via the BSU.

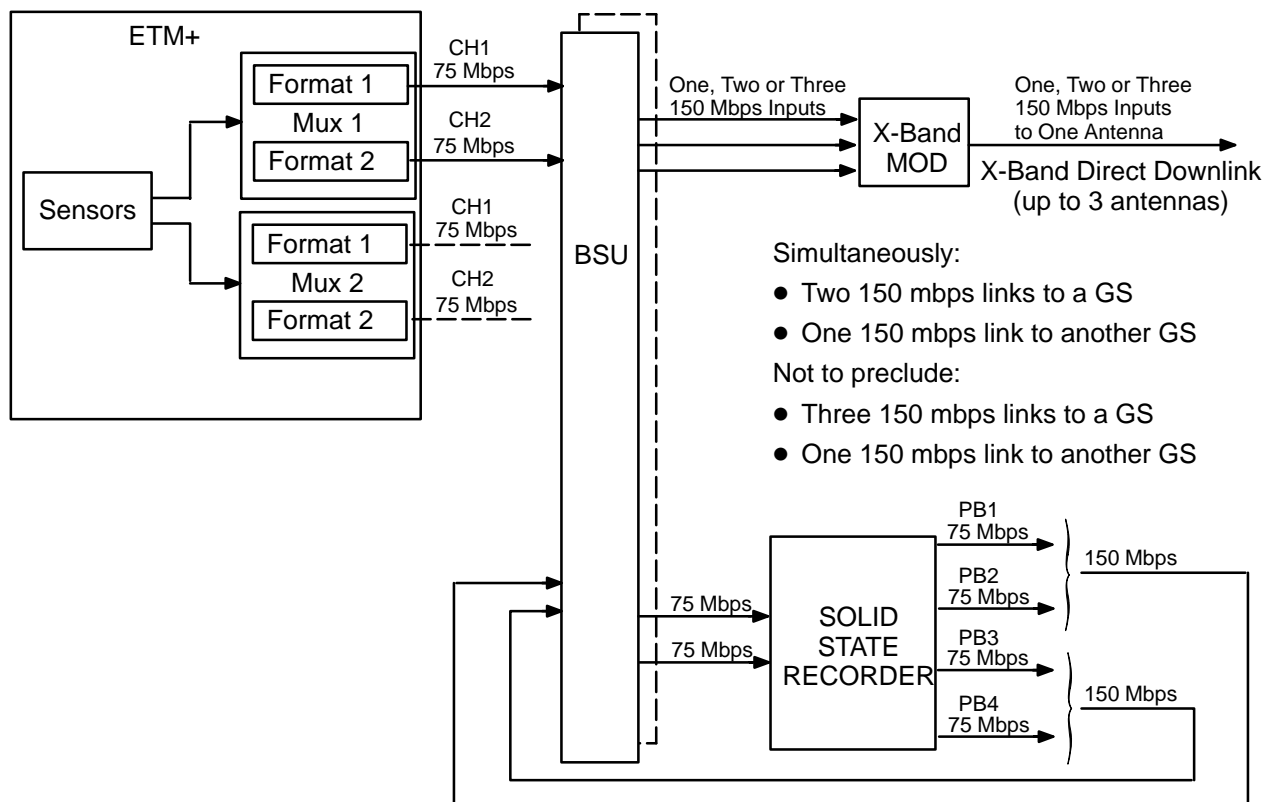

Figure 29. Solid State Recorder Functional Architecture

3.3.2 RECORD FORMAT

The solid state recorders will record ETM+ CADU data as two bitstreams, each at a nominal rate of 74.914 Mbps. CADU data is recorded in the same order as received from the ETM+. Partial CADUs may be recorded if the ETM+ collection interval extends prior to or beyond the commanded SSR record interval. An example of a record format is shown in Figure 30.

3.3.3 PLAYBACK FORMAT

The SSR playback data is read out of memory and mapped into one or two groups of two 75 Mbps bitstreams with a total aggregate rate of 150 or 300 Mbps. The bitstreams consist of the data generated

ETM+ FMT1 (CH1) Recording:

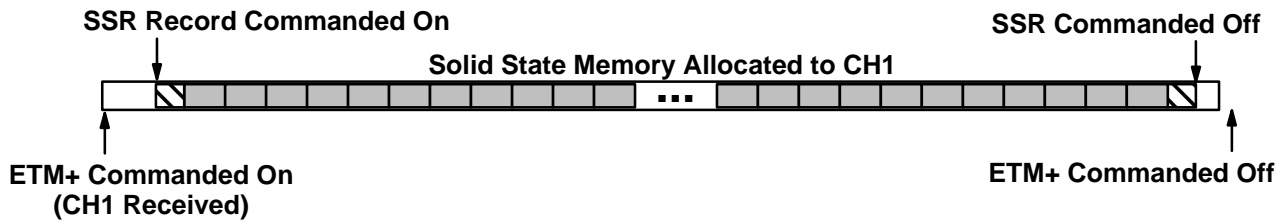

ETM+ FMT2 (CH2) Recording:

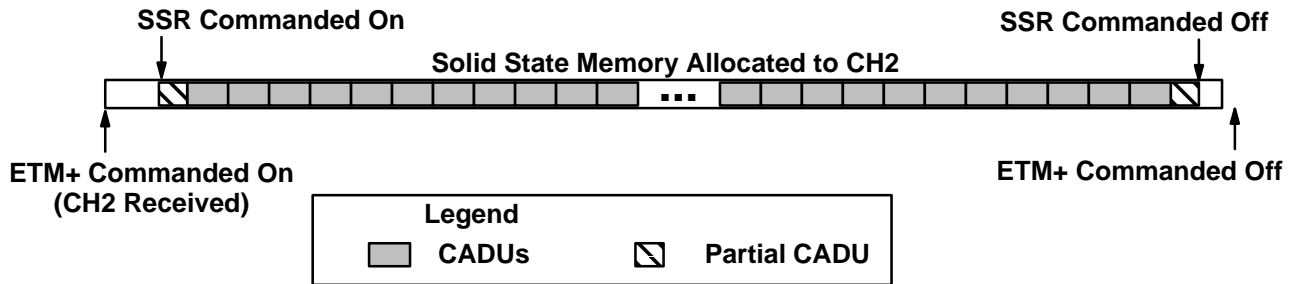
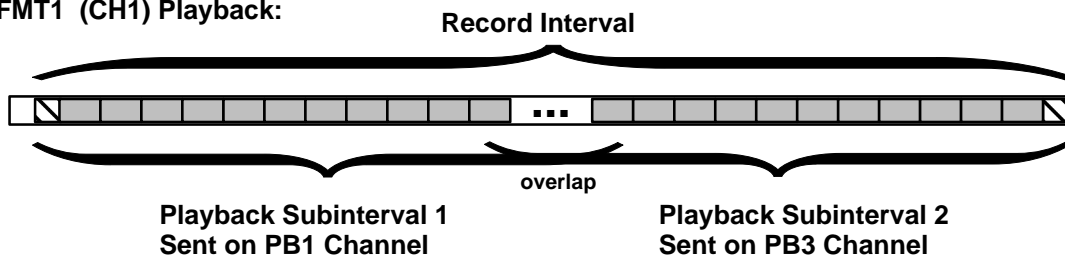

Figure 30. Record Format Example

by the ETM+. Record intervals, each corresponding to a ETM+ collection interval consisting of one or more Landsat scenes, may be subdivided for playback if more than one scene is collected. In this case, each resulting subinterval is defined such that data in the vicinity of each subinterval boundary are included (redundantly) within both subintervals. Each subinterval includes all of the CADU data required to process the subinterval as a separate ETM+ collection. As a result, individual subintervals may contain partial CADUs such as that described in paragraph 3.3.2. An example of the SSR playback is shown in Figure 31. A PN code may precede the SSR playback data for ground station syncing.

ETM+ FMT1 (CH1) Playback:



ETM+ FMT2 (CH2) Playback:

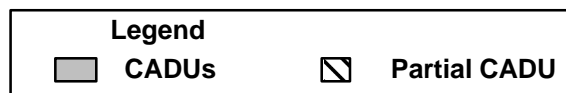
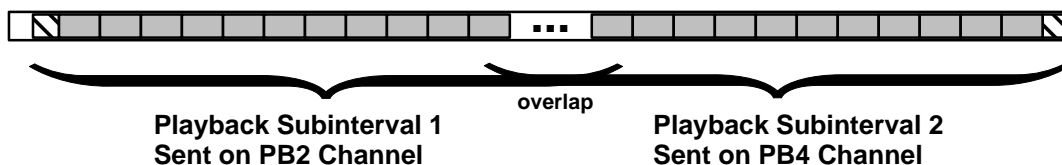

Figure 31. Playback Format Example

**APPENDIX A
ACRONYM LIST**

A/D	Analog/Digital
ADA	Attitude Displacement Assembly
ADS	Attitude Displacement Sensors
AEM	Auxiliary Electronics Module
ASIC	Application Specific Integrated Circuit
BCD	Binary-Coded Decimal
BCH	Bose–Chaudhuri–Hocquenghem
BD	Band
BSU	Baseband Switching Unit
CADU	Channel Access Data Unit
CCSDS	Consultative Committee for Space Data Systems
CFPA	Cold Focal Plane Array
CRC	Cyclic Redundancy Check
DIR	Direction
ECI	Earth Centered Inertial
ECITOD	Earth Centered Inertial True of Date
EDAC	Error Detection and Correction
EOL	End-of-Line
EPA	Euler Parameter
ERR	Error
ETM+	Enhanced Thematic Mapper Plus
FHS	First Half Scan
FMT	Format
HDR	Header
Hex	Hexadecimal
ICD	Interface Control Document

Ifov	Instantaneous Field of View
IGS	International Ground Stations
lsb	Least Significant Bit
IMU	Inertial Measurement Unit
LSB	Least Significant Bit
LWIR	Thermal Long Wavelength Infrared
MBPS	Mega Bits Per Second
msb	Most Significant Bit
MSB	Most Significant Byte
MF	Minor Frame
OSI	Open System Interconnection
PAN	Panchromatic
PCA	Physical Channel Access
PCD	Payload Correction Data
PCSS	Program Coordinate Systems Standards
PFFPA	Prime Focal Plan Assembly
PN	Pseudo-Random Noise
PNTR	Pointer
TBD	To Be Determined
TBR	To Be Resolved
SCID	Spacecraft Identifier
SCN	Scan
SD	Scan Direction
SHS	Second Half Scan
SIG	Signalling
SLL	Scan Line Length
SD	Scan Direction
SLS	Scan Line Start

SV	Space Vehicle
SWIR	Short Wavelength Infrared
VCA	Virtual Channel Access
VCDU	Virtual Channel Data Unit
VCID	Virtual Channel Identifier
VCLC	Virtual Channel Link Control
VER	Version
VNIR	Visible and Near Infrared
YGC	Yaw Gyro Compassing

APPENDIX B REED-SOLOMON CODING

B.1 SPECIFICATION

The parameters of the selected Reed-Solomon (R_S) code are as follows:

- (1) J=4 bits per R-S symbol.
- (2) E= 2 R-S symbols error correction capability within a Reed-Solomon code word.
- (3) General characteristics of Reed-Solomon codes:
 - (a) J,E, and I (the depth of interleaving) are independent parameters.
 - (b) $n= 2^J-1 = 15$ symbols among n symbols of an R-S codeword.
 - (c) 2E is the number of R-S symbols among n symbols of an R-S codeword representing check symbols.
 - (d) $k = n-2E$ is the number of R-S symbols among n R-S symbols of an R-S codeword representing information.
- (4) Field generator polynomial:

$$F(x) = x^4 + x + 1$$

over GF(2).

- (5) Code generator polynomial:

$$g(x) = \prod_{j=6}^9 (x-a^j) = \sum_{i=0}^4 G_i x^i$$

over GF(2⁴).

- (6) It should be recognized that F(x) and g(x) characterize a (15,11) Reed-Solomon code. But since there are not 11 bytes in the header to encode, the R-S code was shortened to a (10,6) RS code. This implies that there are 5 virtual fill symbols. Also note that there is no interleaving.

**B.2 GALOIS FIELD TABLE FOR GF(2⁴) GENERATED BY F(X) FROM NUMBER 4
ABOVE**

P O W E R	POLY IN ALPHA
*	0000
1	0001
2	0100
3	1000
4	0011
5	0110
6	1100
7	1011
8	0101
9	1010
10	0111
11	1110
12	1111
13	1101
14	1001

B.3 EXPANSION OF REED-SOLOMON COEFFICIENTS

COEFFICIENTS OF $g(x)$	POLYNOMIAL IN a
	a^3 a^2 a^1 a^0
$G_0 = G_4 = a^0$	0 0 0 1
$G_1 = G_3 = a^3$	1 0 0 0

APPENDIX C
PAYLOAD CORRECTION DATA (PCD) LATENCIES

C.1 PCD LATENCIES RELATIVE TO PDF TIMECODE IN WIDEBAND DATA

Table C-1 contains Payload Correction Data (listed in the first column) total latencies for 1 Kbps and 4 Kbps telemetry data rates. Case 1 (TDF-Originated) and Case 2 (Flight Software Originated) data are mutually exclusive. Latencies from PCD software buffering and PDF buffering applies to both Case 1 and Case 2.

TABLE C-1. PAYLOAD CORRECTION DATA LATENCIES RELATIVE TO PDF TIME CODE IN WIDEBAND DATA

DESCRIPTION	MAJOR FRAME	MINOR FRAME	DATA SOURCE	CASE 1: TDF-ORIGINATED DATA			CASE 2: FSW-ORIGINATED DATA	LATENCY FROM PCDF S/W BUFFERING AND PDF BUFFERING (SECS)	TOTAL LATENCY (SECS)
				LATENCY FROM INTERRUPT TO DATA AVAILABILITY IN SUBCOM TABLE	LATENCY FROM TDF SAMPLING RATE (SECS)	LATENCY FROM OTHER NON-PCDF FSW			
Ambient Preamp Temperature (High Channels)	2	26	TDF-to-SCP TLM (TEHC-PATMP)	At 1K TLM Rate: Best Case: 0.804 Worst Case: 0.805 At 4K TLM Rate: Best Case: 0.200 Worst Case: 0.201	At 1K TLM Rate: Best Case: 0.012 Worst Case: 0.012 At 4K TLM Rate: Best Case: 0.012 Worst Case: 0.012	At 1K TLM Rate: Best Case: 0.000 Worst Case: 16.000 At 4K TLM Rate: Best Case: 0.000 Worst Case: 4.000	At 1K TLM Rate: Best Case: 0.000 Worst Case: 0.000 At 4K TLM Rate: Best Case: 0.000 Worst Case: 0.000	At 1K TLM Rate: Best Case: 7.691 Worst Case: 8.191 At 4K TLM Rate: Best Case: 7.691 Worst Case: 8.191	At 1K TLM Rate: Best Case: 8.507 Worst Case: 25.008 At 4K TLM Rate: Best Case: 7.903 Worst Case: 12.404
Ambient Preamp Temperature (Low Channels)	2	30	TDF-to-SCP TLM (TELCATMP)	At 1K TLM Rate: Best Case: 0.796 Worst Case: 0.797 At 4K TLM Rate: Best Case: 0.198 Worst Case: 0.199	At 1K TLM Rate: Best Case: 0.012 Worst Case: 0.012 At 4K TLM Rate: Best Case: 0.012 Worst Case: 0.012	At 1K TLM Rate: Best Case: 0.000 Worst Case: 16.000 At 4K TLM Rate: Best Case: 0.000 Worst Case: 4.000	At 1K TLM Rate: Best Case: 0.000 Worst Case: 0.000 At 4K TLM Rate: Best Case: 0.000 Worst Case: 0.000	At 1K TLM Rate: Best Case: 7.691 Worst Case: 8.191 At 4K TLM Rate: Best Case: 7.691 Worst Case: 8.191	At 1K TLM Rate: Best Case: 8.499 Worst Case: 25.000 At 4K TLM Rate: Best Case: 7.901 Worst Case: 12.402
Backup Shutter Flag Temperature	0, 1, 2, 3	77	TDF-to-SCP TLM (TEBSHTMP)	At 1K TLM Rate: Best Case: 0.858 Worst Case: 0.859 At 4K TLM Rate: Best Case: 0.214 Worst Case: 0.215	At 1K TLM Rate: Best Case: 0.012 Worst Case: 0.012 At 4K TLM Rate: Best Case: 0.012 Worst Case: 0.012	At 1K TLM Rate: Best Case: 0.000 Worst Case: 4.000 At 4K TLM Rate: Best Case: 0.000 Worst Case: 1.000	At 1K TLM Rate: Best Case: 0.000 Worst Case: 0.000 At 4K TLM Rate: Best Case: 0.000 Worst Case: 0.000	At 1K TLM Rate: Best Case: 7.691 Worst Case: 8.191 At 4K TLM Rate: Best Case: 7.691 Worst Case: 8.191	At 1K TLM Rate: Best Case: 8.561 Worst Case: 13.062 At 4K TLM Rate: Best Case: 7.917 Worst Case: 9.418

TABLE C-1. PAYLOAD CORRECTION DATA LATENCIES RELATIVE TO PDF TIME CODE IN WIDEBAND DATA

DESCRIPTION	MAJOR FRAME	MINOR FRAME	DATA SOURCE	CASE 1: TDF-ORIGINATED DATA			CASE 2: FSW-ORIGINATED DATA	LATENCY FROM PCDF S/W BUFFERING AND PDF BUFFERING (SECS)	TOTAL LATENCY (SECS)
				LATENCY FROM INTERRUPT TO DATA AVAILABILITY IN SUBCOM TABLE	LATENCY FROM TDF SAMPLING RATE (SECS)	LATENCY FROM OTHER NON-PCDF FSW			
Baffle Temperature (Heater)	0, 1, 2, 3	79	TDF-to-SCP TLM (TEBFHTRTM P)	At 1K TLM Rate: Best Case: 0.012 Worst Case: 0.012	At 1K TLM Rate: Best Case: 0.000 Worst Case: 4.000	At 1K TLM Rate: Best Case: 0.000 Worst Case: 0.000	At 1K TLM Rate: Best Case: 7.691 Worst Case: 8.191	At 1K TLM Rate: Best Case: 8.538 Worst Case: 13.039	
Baffle Temperature (Support)	2	22	TDF-to-SCP TLM (TEBFSPTMP)	At 1K TLM Rate: Best Case: 0.208 Worst Case: 0.209	At 1K TLM Rate: Best Case: 0.000 Worst Case: 16.000	At 1K TLM Rate: Best Case: 0.000 Worst Case: 0.000	At 1K TLM Rate: Best Case: 7.691 Worst Case: 8.191	At 1K TLM Rate: Best Case: 7.911 Worst Case: 9.412	
Baffle Temperature (Tube)	2	19	TDF-to-SCP TLM (TEBFTBTMP)	At 1K TLM Rate: Best Case: 0.196 Worst Case: 0.197	At 1K TLM Rate: Best Case: 0.000 Worst Case: 16.000	At 1K TLM Rate: Best Case: 0.000 Worst Case: 0.000	At 1K TLM Rate: Best Case: 7.691 Worst Case: 8.191	At 1K TLM Rate: Best Case: 7.899 Worst Case: 12.400	

TABLE C-1. PAYLOAD CORRECTION DATA LATENCIES RELATIVE TO PDF TIME CODE IN WIDEBAND DATA

DESCRIPTION	MAJOR FRAME	MINOR FRAME	DATA SOURCE	CASE 1: TDF-ORIGINATED DATA			CASE 2: FSW-ORIGINATED DATA	LATENCY FROM PC/D S/W BUFFERING AND PDF BUFFERING (SECS)	TOTAL LATENCY (SECS)
				LATENCY FROM INTERRUPT TO DATA AVAIL-ABILITY IN SUBCOM TABLE	LATENCY FROM TDF SAMPLING RATE (SECS)	LATENCY FROM OTHER NON-PC/D FSW			
Band 4 Post Amp Temperature	2	27	TDF-to-SCP TLM (TEB4PATMP)	LATENCY FROM DATA SAMPLING BY TDF TO LEVEL 10 INTERRUPT (SECS)	LATENCY FROM TDF SAMPLING RATE (SECS)	LATENCY FROM OTHER NON-PC/D FSW	LATENCY FROM PC/D S/W BUFFERING AND PDF BUFFERING (SECS)	TOTAL LATENCY (SECS)	
				At 1K TLM Rate: Best Case: 0.812 Worst Case: 0.813	At 1K TLM Rate: Best Case: 0.000 Worst Case: 16.000	At 1K TLM Rate: Best Case: 0.000 Worst Case: 0.000	At 1K TLM Rate: Best Case: 7.691 Worst Case: 8.191	At 1K TLM Rate: Best Case: 8.515 Worst Case: 25.016	
Band 7 Preamp Temperature	2	29	TDF-to-SCP TLM (TEB7PATMP)	LATENCY FROM INTERRUPT TO DATA AVAIL-ABILITY IN SUBCOM TABLE	LATENCY FROM TDF SAMPLING RATE (SECS)	LATENCY FROM OTHER NON-PC/D FSW	LATENCY FROM PC/D S/W BUFFERING AND PDF BUFFERING (SECS)	TOTAL LATENCY (SECS)	
				At 1K TLM Rate: Best Case: 0.202 Worst Case: 0.203	At 4K TLM Rate: Best Case: 0.000 Worst Case: 4.000	At 4K TLM Rate: Best Case: 0.000 Worst Case: 0.000	At 4K TLM Rate: Best Case: 7.691 Worst Case: 8.191	At 4K TLM Rate: Best Case: 7.905 Worst Case: 12.406	
Black Body Temperature (Control)	0, 1, 2, 3	78	TDF-to-SCP TLM (TEBBCTMP)	LATENCY FROM INTERRUPT TO DATA AVAIL-ABILITY IN SUBCOM TABLE	LATENCY FROM TDF SAMPLING RATE (SECS)	LATENCY FROM OTHER NON-PC/D FSW	LATENCY FROM PC/D S/W BUFFERING AND PDF BUFFERING (SECS)	TOTAL LATENCY (SECS)	
				At 1K TLM Rate: Best Case: 0.851 Worst Case: 0.852	At 1K TLM Rate: Best Case: 0.000 Worst Case: 4.000	At 1K TLM Rate: Best Case: 0.000 Worst Case: 0.000	At 1K TLM Rate: Best Case: 7.691 Worst Case: 8.191	At 1K TLM Rate: Best Case: 8.554 Worst Case: 13.055	

TABLE C-1. PAYLOAD CORRECTION DATA LATENCIES RELATIVE TO PDF TIME CODE IN WIDEBAND DATA

DESCRIPTION	MAJOR FRAME	MINOR FRAME	DATA SOURCE	CASE 1: TDF-ORIGINATED DATA			CASE 2: FSW-ORIGINATED DATA	LATENCY FROM PC/D S/W BUFFERING AND PDF BUFFERING (SECS)	TOTAL LATENCY (SECS)
				LATENCY FROM INTERRUPT TO DATA AVAILABILITY IN SUBCOM TABLE	LATENCY FROM TDF SAMPLING RATE (SECS)	LATENCY FROM OTHER NON-PC/D FSW			
Black Body Temperature (Isolated)	0, 1, 2, 3	74	TDF-to-SCP TLM (TEBBMTMP)	<p><u>At 1K TLM Rate:</u> Best Case: 0.843 Worst Case: 0.844</p> <p><u>At 4K TLM Rate:</u> Best Case: 0.210 Worst Case: 0.211</p>	<p><u>At 1K TLM Rate:</u> Best Case: 0.012 Worst Case: 0.012</p> <p><u>At 4K TLM Rate:</u> Best Case: 0.012 Worst Case: 0.012</p>	<p><u>At 1K TLM Rate:</u> Best Case: 0.000 Worst Case: 4.000</p> <p><u>At 4K TLM Rate:</u> Best Case: 0.000 Worst Case: 1.000</p>	<p><u>At 1K TLM Rate:</u> Best Case: 7.691 Worst Case: 8.191</p> <p><u>At 4K TLM Rate:</u> Best Case: 7.691 Worst Case: 8.191</p>	<p><u>At 1K TLM Rate:</u> Best Case: 8.546 Worst Case: 13.047</p> <p><u>At 4K TLM Rate:</u> Best Case: 7.913 Worst Case: 9.414</p>	
Calibration Lamp Housing Temperature	2	23	TDF-to-SCP TLM (TE-CLAMPHT)	<p><u>At 1K TLM Rate:</u> Best Case: 0.772 Worst Case: 0.773</p> <p><u>At 4K TLM Rate:</u> Best Case: 0.192 Worst Case: 0.193</p>	<p><u>At 1K TLM Rate:</u> Best Case: 0.012 Worst Case: 0.012</p> <p><u>At 4K TLM Rate:</u> Best Case: 0.012 Worst Case: 0.012</p>	<p><u>At 1K TLM Rate:</u> Best Case: 0.000 Worst Case: 16.000</p> <p><u>At 4K TLM Rate:</u> Best Case: 0.000 Worst Case: 4.000</p>	<p><u>At 1K TLM Rate:</u> Best Case: 7.691 Worst Case: 8.191</p> <p><u>At 4K TLM Rate:</u> Best Case: 7.691 Worst Case: 8.191</p>	<p><u>At 1K TLM Rate:</u> Best Case: 8.475 Worst Case: 24.976</p> <p><u>At 4K TLM Rate:</u> Best Case: 7.895 Worst Case: 12.396</p>	
Calibration Shutter Flag Temperature	0, 1, 2, 3	76	TDF-to-SCP TLM (TECSFTMP)	<p><u>At 1K TLM Rate:</u> Best Case: 0.835 Worst Case: 0.836</p> <p><u>At 4K TLM Rate:</u> Best Case: 0.208 Worst Case: 0.209</p>	<p><u>At 1K TLM Rate:</u> Best Case: 0.012 Worst Case: 0.012</p> <p><u>At 4K TLM Rate:</u> Best Case: 0.012 Worst Case: 0.012</p>	<p><u>At 1K TLM Rate:</u> Best Case: 0.000 Worst Case: 4.000</p> <p><u>At 4K TLM Rate:</u> Best Case: 0.000 Worst Case: 1.000</p>	<p><u>At 1K TLM Rate:</u> Best Case: 7.691 Worst Case: 8.191</p> <p><u>At 4K TLM Rate:</u> Best Case: 7.691 Worst Case: 8.191</p>	<p><u>At 1K TLM Rate:</u> Best Case: 8.538 Worst Case: 13.039</p> <p><u>At 4K TLM Rate:</u> Best Case: 7.911 Worst Case: 9.412</p>	

TABLE C-1. PAYLOAD CORRECTION DATA LATENCIES RELATIVE TO PDF TIME CODE IN WIDEBAND DATA

DESCRIPTION	MAJOR FRAME	MINOR FRAME	DATA SOURCE	CASE 1: TDF-ORIGINATED DATA			CASE 2: FSW-ORIGINATED DATA	LATENCY FROM PC/D S/W BUFFERING AND PDF BUFFERING (SECS)	TOTAL LATENCY (SECS)
				LATENCY FROM DATA SAMPLING BY TDF TO LEVEL 10 INTERRUPT (SECS)	LATENCY FROM INTERRUPT TO DATA AVAILABILITY IN SUBCOM TABLE	LATENCY FROM TDF SAMPLING RATE (SECS)			
Calibration Shutter Hub Temperature	2	25	TDF-to-SCP TLM (TECSHHBTMP)	At 1K TLM Rate: Best Case: 0.812 Worst Case: 0.813 At 4K TLM Rate: Best Case: 0.202 Worst Case: 0.203	At 1K TLM Rate: Best Case: 0.012 Worst Case: 0.012 At 4K TLM Rate: Best Case: 0.012 Worst Case: 0.012	At 1K TLM Rate: Best Case: 0.000 Worst Case: 16.000 At 4K TLM Rate: Best Case: 0.000 Worst Case: 4.000	At 1K TLM Rate: Best Case: 0.000 Worst Case: 0.000 At 4K TLM Rate: Best Case: 0.000 Worst Case: 0.000	At 1K TLM Rate: Best Case: 7.691 Worst Case: 8.191 At 4K TLM Rate: Best Case: 7.691 Worst Case: 8.191	At 1K TLM Rate: Best Case: 8.515 Worst Case: 25.016 At 4K TLM Rate: Best Case: 7.905 Worst Case: 12.406
CFPA Control Temperature	0, 1, 2, 3	80	TDF-to-SCP TLM (TECF-PACTMP)	At 1K TLM Rate: Best Case: 0.851 Worst Case: 0.852 At 4K TLM Rate: Best Case: 0.212 Worst Case: 0.213	At 1K TLM Rate: Best Case: 0.012 Worst Case: 0.012 At 4K TLM Rate: Best Case: 0.012 Worst Case: 0.012	At 1K TLM Rate: Best Case: 0.000 Worst Case: 4.000 At 4K TLM Rate: Best Case: 0.000 Worst Case: 1.000	At 1K TLM Rate: Best Case: 0.000 Worst Case: 0.000 At 4K TLM Rate: Best Case: 0.000 Worst Case: 0.000	At 1K TLM Rate: Best Case: 7.691 Worst Case: 8.191 At 4K TLM Rate: Best Case: 7.691 Worst Case: 8.191	At 1K TLM Rate: Best Case: 8.554 Worst Case: 13.055 At 4K TLM Rate: Best Case: 7.915 Worst Case: 9.416
CFPA Heater Current	0, 1, 2, 3	75	TDF-to-SCP TLM (TECFPAH-TRI)	At 1K TLM Rate: Best Case: 0.843 Worst Case: 0.844 At 4K TLM Rate: Best Case: 0.210 Worst Case: 0.211	At 1K TLM Rate: Best Case: 0.012 Worst Case: 0.012 At 4K TLM Rate: Best Case: 0.012 Worst Case: 0.012	At 1K TLM Rate: Best Case: 0.000 Worst Case: 4.000 At 4K TLM Rate: Best Case: 0.000 Worst Case: 1.000	At 1K TLM Rate: Best Case: 0.000 Worst Case: 0.000 At 4K TLM Rate: Best Case: 0.000 Worst Case: 0.000	At 1K TLM Rate: Best Case: 7.691 Worst Case: 8.191 At 4K TLM Rate: Best Case: 7.691 Worst Case: 8.191	At 1K TLM Rate: Best Case: 8.546 Worst Case: 13.047 At 4K TLM Rate: Best Case: 7.913 Worst Case: 9.414

TABLE C-1. PAYLOAD CORRECTION DATA LATENCIES RELATIVE TO PDF TIME CODE IN WIDEBAND DATA

DESCRIPTION	MAJOR FRAME	MINOR FRAME	DATA SOURCE	CASE 1: TDF-ORIGINATED DATA			CASE 2: FSW-ORIGINATED DATA	LATENCY FROM PCDF S/W BUFFERING AND PDF BUFFERING (SECS)	TOTAL LATENCY (SECS)
				LATENCY FROM LEVEL 10 INTERRUPT TO DATA AVAIL-ABILITY IN SUBCOM TABLE	LATENCY FROM DATA SAMPLING BY TDF TO LEVEL 10 INTERRUPT TO FSW (SECS)	LATENCY FROM TDF SAMPLING RATE (SECS)			
Cold FPA Monitor Temperature	2	21	TDF-to-SCP TLM (TECF-PAMTMP)	At 1K TLM Rate: Best Case: 0.012 Worst Case: 0.012	At 1K TLM Rate: Best Case: 0.780 Worst Case: 0.781	At 1K TLM Rate: Best Case: 0.000 Worst Case: 16.000	At 1K TLM Rate: Best Case: 7.691 Worst Case: 8.191	At 1K TLM Rate: Best Case: 8.483 Worst Case: 24.984	
				At 4K TLM Rate: Best Case: 0.194 Worst Case: 0.195	At 4K TLM Rate: Best Case: 0.000 Worst Case: 4.000	At 4K TLM Rate: Best Case: 0.000 Worst Case: 0.000	At 4K TLM Rate: Best Case: 7.691 Worst Case: 8.191	At 4K TLM Rate: Best Case: 7.897 Worst Case: 12.398	
				N/A	N/A	N/A	At 1K TLM Rate: Best Case: 0.000 Worst Case: 0.000	At 1K TLM Rate: Best Case: 7.691 Worst Case: 8.191	At 1K TLM Rate: Best Case: 7.691 Worst Case: 8.191
				N/A	N/A	N/A	At 4K TLM Rate: Best Case: 0.000 Worst Case: 0.000	At 4K TLM Rate: Best Case: 7.691 Worst Case: 8.191	At 4K TLM Rate: Best Case: 7.691 Worst Case: 8.191
Ephemeris Position (X)	0	50-53	Interpolation of ACSDEF.VR	N/A	N/A	N/A	At 1K TLM Rate: Best Case: 0.000 Worst Case: 0.000	At 1K TLM Rate: Best Case: 7.691 Worst Case: 8.191	
	1	16-19		At 1K TLM Rate: Best Case: 0.000 Worst Case: 0.000	At 1K TLM Rate: Best Case: 0.000 Worst Case: 0.000	At 1K TLM Rate: Best Case: 0.000 Worst Case: 0.000	At 1K TLM Rate: Best Case: 7.691 Worst Case: 8.191	At 1K TLM Rate: Best Case: 7.691 Worst Case: 8.191	
	2	50-53		At 4K TLM Rate: Best Case: 0.000 Worst Case: 0.000	At 4K TLM Rate: Best Case: 0.000 Worst Case: 0.000	At 4K TLM Rate: Best Case: 0.000 Worst Case: 0.000	At 4K TLM Rate: Best Case: 7.691 Worst Case: 8.191	At 4K TLM Rate: Best Case: 7.691 Worst Case: 8.191	
	3	16-19		At 1K TLM Rate: Best Case: 0.000 Worst Case: 0.000	At 1K TLM Rate: Best Case: 0.000 Worst Case: 0.000	At 1K TLM Rate: Best Case: 0.000 Worst Case: 0.000	At 1K TLM Rate: Best Case: 7.691 Worst Case: 8.191	At 1K TLM Rate: Best Case: 7.691 Worst Case: 8.191	
Ephemeris Position (Y)	0	54-57	Interpolation of ACSDEF.VR	N/A	N/A	N/A	At 1K TLM Rate: Best Case: 0.000 Worst Case: 0.000	At 1K TLM Rate: Best Case: 7.691 Worst Case: 8.191	
	1	20-23		At 1K TLM Rate: Best Case: 0.000 Worst Case: 0.000	At 1K TLM Rate: Best Case: 0.000 Worst Case: 0.000	At 1K TLM Rate: Best Case: 0.000 Worst Case: 0.000	At 1K TLM Rate: Best Case: 7.691 Worst Case: 8.191	At 1K TLM Rate: Best Case: 7.691 Worst Case: 8.191	
	2	54-57		At 4K TLM Rate: Best Case: 0.000 Worst Case: 0.000	At 4K TLM Rate: Best Case: 0.000 Worst Case: 0.000	At 4K TLM Rate: Best Case: 0.000 Worst Case: 0.000	At 4K TLM Rate: Best Case: 7.691 Worst Case: 8.191	At 4K TLM Rate: Best Case: 7.691 Worst Case: 8.191	
	3	20-23		At 1K TLM Rate: Best Case: 0.000 Worst Case: 0.000	At 1K TLM Rate: Best Case: 0.000 Worst Case: 0.000	At 1K TLM Rate: Best Case: 0.000 Worst Case: 0.000	At 1K TLM Rate: Best Case: 7.691 Worst Case: 8.191	At 1K TLM Rate: Best Case: 7.691 Worst Case: 8.191	

TABLE C-1. PAYLOAD CORRECTION DATA LATENCIES RELATIVE TO PDF TIME CODE IN WIDEBAND DATA

DESCRIPTION	CASE 1: TDF-ORIGINATED DATA				CASE 2: FSW- ORIGINATED DATA	LATENCY FROM PC/D S/W BUFFERING AND PDF BUFFERING (SECS)	TOTAL LATENCY (SECS)
	MAJOR FRAME	MINOR FRAME	DATA SOURCE	LATENCY FROM LEVEL 10 INTERRUPT TO DATA AVAIL- ABILITY IN SUBCOM TABLE			
Ephemeris Position (Z)	0	58-61	Interpolation of ACSDEF.VR	N/A	N/A	At 1K TLM Rate: Best Case: 7.691 Worst Case: 8.191	At 1K TLM Rate: Best Case: 7.691 Worst Case: 8.191
	1	24-27		N/A	At 1K TLM Rate: Best Case: 0.000 Worst Case: 0.000	At 1K TLM Rate: Best Case: 7.691 Worst Case: 8.191	
	2	58-61		N/A	At 4K TLM Rate: Best Case: 0.000 Worst Case: 0.000	At 4K TLM Rate: Best Case: 7.691 Worst Case: 8.191	
	3	24-27		N/A	At 4K TLM Rate: Best Case: 0.000 Worst Case: 0.000	At 4K TLM Rate: Best Case: 7.691 Worst Case: 8.191	
Ephemeris Velocity (X)	0	62-65	Interpolation of ACSDEF.VV	N/A	N/A	At 1K TLM Rate: Best Case: 7.691 Worst Case: 8.191	At 1K TLM Rate: Best Case: 7.691 Worst Case: 8.191
	1	28-31		N/A	At 1K TLM Rate: Best Case: 0.000 Worst Case: 0.000	At 1K TLM Rate: Best Case: 7.691 Worst Case: 8.191	
	2	62-65		N/A	At 4K TLM Rate: Best Case: 0.000 Worst Case: 0.000	At 4K TLM Rate: Best Case: 7.691 Worst Case: 8.191	
	3	28-31		N/A	At 4K TLM Rate: Best Case: 0.000 Worst Case: 0.000	At 4K TLM Rate: Best Case: 7.691 Worst Case: 8.191	
Ephemeris Velocity (Y)	0	66-69	Interpolation of ACSDEF.VV	N/A	N/A	At 1K TLM Rate: Best Case: 7.691 Worst Case: 8.191	At 1K TLM Rate: Best Case: 7.691 Worst Case: 8.191
	1	32-35		N/A	At 1K TLM Rate: Best Case: 0.000 Worst Case: 0.000	At 1K TLM Rate: Best Case: 7.691 Worst Case: 8.191	
	2	66-69		N/A	At 4K TLM Rate: Best Case: 0.000 Worst Case: 0.000	At 4K TLM Rate: Best Case: 7.691 Worst Case: 8.191	
	3	32-35		N/A	At 4K TLM Rate: Best Case: 0.000 Worst Case: 0.000	At 4K TLM Rate: Best Case: 7.691 Worst Case: 8.191	

TABLE C-1. PAYLOAD CORRECTION DATA LATENCIES RELATIVE TO PDF TIME CODE IN WIDEBAND DATA

DESCRIPTION	CASE 1: TDF-ORIGINATED DATA				CASE 2: FSW- ORIGINATED DATA	LATENCY FROM PC/D S/W BUFFERING AND PDF BUFFERING (SECS)	TOTAL LATENCY (SECS)
	MAJOR FRAME	MINOR FRAME	DATA SOURCE	LATENCY FROM LEVEL 10 INTERRUPT TO DATA AVAIL- ABILITY IN SUBCOM TABLE			
Ephemeris Velocity (Z)	0	70-73	Interpolation of ACSDEF.VV	N/A	N/A	At 1K TLM Rate: Best Case: 0.000 Worst Case: 0.000	At 1K TLM Rate: Best Case: 7.691 Worst Case: 8.191
	1	36-39		N/A	N/A	At 4K TLM Rate: Best Case: 0.000 Worst Case: 0.000	At 4K TLM Rate: Best Case: 7.691 Worst Case: 8.191
	2	70-73		N/A	N/A	At 1K TLM Rate: Best Case: 0.000 Worst Case: 0.000	At 1K TLM Rate: Best Case: 7.691 Worst Case: 8.191
	3	36-39		N/A	N/A	At 4K TLM Rate: Best Case: 0.000 Worst Case: 0.000	At 4K TLM Rate: Best Case: 7.691 Worst Case: 8.191
ETM+Off Time	0	84-89	Derived from TDF-to-SCP TLM (TEPS1AI, TEPS1BI, TEPS2AI, TEPS2BI)	At 1K TLM Rate: Best Case: 0.796 Worst Case: 0.797	At 1K TLM Rate: Best Case: 0.000 Worst Case: 16.000	At 1K TLM Rate: Best Case: 0.000 Worst Case: 0.000	At 1K TLM Rate: Best Case: 8.499 Worst Case: 25.000
				At 4K TLM Rate: Best Case: 0.198 Worst Case: 0.199	At 4K TLM Rate: Best Case: 0.000 Worst Case: 4.000	At 4K TLM Rate: Best Case: 0.000 Worst Case: 0.000	At 4K TLM Rate: Best Case: 7.901 Worst Case: 12.402
ETM+On Time	0	42-47	Derived from TDF-to-SCP TLM (TEPS1AI, TEPS1BI, TEPS2AI, TEPS2BI)	At 1K TLM Rate: Best Case: 0.796 Worst Case: 0.797	At 1K TLM Rate: Best Case: 0.000 Worst Case: 16.000	At 1K TLM Rate: Best Case: 0.000 Worst Case: 0.000	At 1K TLM Rate: Best Case: 8.499 Worst Case: 25.000
				At 4K TLM Rate: Best Case: 0.198 Worst Case: 0.199	At 4K TLM Rate: Best Case: 0.000 Worst Case: 4.000	At 4K TLM Rate: Best Case: 0.000 Worst Case: 0.000	At 4K TLM Rate: Best Case: 7.901 Worst Case: 12.402

TABLE C-1. PAYLOAD CORRECTION DATA LATENCIES RELATIVE TO PDF TIME CODE IN WIDEBAND DATA

DESCRIPTION	MAJOR FRAME	MINOR FRAME	DATA SOURCE	CASE 1: TDF-ORIGINATED DATA			CASE 2: FSW-ORIGINATED DATA	LATENCY FROM PCDF S/W BUFFERING AND PDF BUFFERING (SECS)	TOTAL LATENCY (SECS)
				LATENCY FROM DATA SAMPLING BY TDF TO LEVEL 10 INTERRUPT TO FSW (SECS)	LATENCY FROM LEVEL 10 INTERRUPT TO DATA AVAILABILITY IN SUBCOM TABLE	LATENCY FROM TDF SAMPLING RATE (SECS)			
Euler Parameter 1 (EPA 1)	0, 1, 2, 3	0-3	<u>PRADS</u> : Interpolation of PADDEF:EPA <u>BACKUP</u> : Extrapolation of ACSDEF, AROLL, APITCH, GCYAW	N/A	N/A	N/A	At 1K TLM Rate: Best Case: 7.691 Worst Case: 8.191 At 4K TLM Rate: Best Case: 7.691 Worst Case: 8.191	At 1K TLM Rate: Best Case: 7.691 Worst Case: 8.191 At 4K TLM Rate: Best Case: 7.691 Worst Case: 8.191	
Euler Parameter 2 (EPA 2)	0, 1, 2, 3	4-7	<u>PRADS</u> : Interpolation of PADDEF:EPA <u>BACKUP</u> : Extrapolation of ACSDEF, AROLL, APITCH, GCYAW	N/A	N/A	N/A	At 1K TLM Rate: Best Case: 0.000 Worst Case: 0.000 At 4K TLM Rate: Best Case: 0.000 Worst Case: 0.000	At 1K TLM Rate: Best Case: 7.691 Worst Case: 8.191 At 4K TLM Rate: Best Case: 7.691 Worst Case: 8.191	
Euler Parameter 3 (EPA 3)	0, 1, 2, 3	8-11	<u>PRADS</u> : Interpolation of PADDEF:EPA <u>BACKUP</u> : Extrapolation of ACSDEF, AROLL, APITCH, GCYAW	N/A	N/A	N/A	At 1K TLM Rate: Best Case: 0.000 Worst Case: 0.000 At 4K TLM Rate: Best Case: 0.000 Worst Case: 0.000	At 1K TLM Rate: Best Case: 7.691 Worst Case: 8.191 At 4K TLM Rate: Best Case: 7.691 Worst Case: 8.191	

TABLE C-1. PAYLOAD CORRECTION DATA LATENCIES RELATIVE TO PDF TIME CODE IN WIDEBAND DATA

DESCRIPTION	MAJOR FRAME	MINOR FRAME	DATA SOURCE	CASE 1: TDF-ORIGINATED DATA			CASE 2: FSW-ORIGINATED DATA	LATENCY FROM PCD S/W BUFFERING AND PDF BUFFERING (SECS)	TOTAL LATENCY (SECS)
				LATENCY FROM LEVEL 10 INTERRUPT TO DATA AVAILABILITY IN SUBCOM TABLE	LATENCY FROM DATA SAMPLING BY TDF TO LEVEL 10 INTERRUPT TO FSW (SECS)	LATENCY FROM TDF SAMPLING RATE (SECS)			
Euler Parameter 4 (EPA 4)	0, 1, 2, 3	12-15	PRADS: Interpolation of PADDEF/EPA BACKUP: Extrapolation of ACSDEF, AROLL, APITCH, GCYAW	N/A	N/A	N/A	At 1K TLM Rate: Best Case: 7.691 Worst Case: 8.191 At 4K TLM Rate: Best Case: 7.691 Worst Case: 8.191	At 1K TLM Rate: Best Case: 7.691 Worst Case: 8.191 At 4K TLM Rate: Best Case: 7.691 Worst Case: 8.191	
Gyro Drift (Theta BX)	0	16-19	PADDEF. STATES	N/A	N/A	N/A	At 1K TLM Rate: Best Case: 0.400 Worst Case: 0.400 At 4K TLM Rate: Best Case: 0.400 Worst Case: 0.400	At 1K TLM Rate: Best Case: 8.091 Worst Case: 8.591 At 4K TLM Rate: Best Case: 8.091 Worst Case: 8.591	
Gyro Drift (Theta BY)	0	20-23	PADDEF. STATES	N/A	N/A	N/A	At 1K TLM Rate: Best Case: 0.400 Worst Case: 0.400 At 4K TLM Rate: Best Case: 0.400 Worst Case: 0.400	At 1K TLM Rate: Best Case: 8.091 Worst Case: 8.591 At 4K TLM Rate: Best Case: 8.091 Worst Case: 8.591	

TABLE C-1. PAYLOAD CORRECTION DATA LATENCIES RELATIVE TO PDF TIME CODE IN WIDEBAND DATA

DESCRIPTION	MAJOR FRAME	MINOR FRAME	DATA SOURCE	CASE 1: TDF-ORIGINATED DATA			CASE 2: FSW-ORIGINATED DATA	LATENCY FROM PC/D S/W BUFFERING AND PDF BUFFERING (SECS)	TOTAL LATENCY (SECS)
				LATENCY FROM DATA SAMPLING BY TDF TO LEVEL 10 INTERRUPT TO FSW (SECS)	LATENCY FROM LEVEL 10 INTERRUPT TO DATA AVAILABILITY IN SUBCOM TABLE	LATENCY FROM TDF SAMPLING RATE (SECS)			
Gyro Drift (Theta BZ)	0	24-27	PADDEF. STATES	N/A	N/A	N/A	At 1K TLM Rate: Best Case: 0.400 Worst Case: 0.400	At 1K TLM Rate: Best Case: 8.091 Worst Case: 8.591	
Gyro Select Data	0	34	Derived from TDF-to-SCP TLM (TACSAST, TDCDHPWRS T)	At 1K TLM Rate: Best Case: 0.788 Worst Case: 0.789	At 1K TLM Rate: Best Case: 0.012 Worst Case: 0.012	At 1K TLM Rate: Best Case: 0.000 Worst Case: 16.000	At 1K TLM Rate: Best Case: 7.691 Worst Case: 8.191	At 1K TLM Rate: Best Case: 8.491 Worst Case: 24.992	
MEM Heat Sink Power Supply 1 Temperature	2	16	TDF-to-SCP TLM (TEPS1HSTM P)	At 1K TLM Rate: Best Case: 0.812 Worst Case: 0.813	At 1K TLM Rate: Best Case: 0.012 Worst Case: 0.012	At 1K TLM Rate: Best Case: 0.000 Worst Case: 16.000	At 1K TLM Rate: Best Case: 7.691 Worst Case: 8.191	At 1K TLM Rate: Best Case: 8.515 Worst Case: 25.016	
				At 4K TLM Rate: Best Case: 0.196 Worst Case: 0.197	At 4K TLM Rate: Best Case: 0.012 Worst Case: 0.012	At 4K TLM Rate: Best Case: 0.000 Worst Case: 4.000	At 4K TLM Rate: Best Case: 7.691 Worst Case: 8.191	At 4K TLM Rate: Best Case: 8.091 Worst Case: 8.591	

TABLE C-1. PAYLOAD CORRECTION DATA LATENCIES RELATIVE TO PDF TIME CODE IN WIDEBAND DATA

DESCRIPTION	MAJOR FRAME	MINOR FRAME	DATA SOURCE	CASE 1: TDF-ORIGINATED DATA			CASE 2: FSW-ORIGINATED DATA	LATENCY FROM PC/D S/W BUFFERING AND PDF BUFFERING (SECS)	TOTAL LATENCY (SECS)
				LATENCY FROM INTERRUPT TO DATA AVAIL-ABILITY IN SUBCOM TABLE	LATENCY FROM TDF SAMPLING RATE (SECS)	LATENCY FROM OTHER NON-PC/D FSW			
MEM Heat Sink Power Supply 2 Temperature	2	20	TDF-to-SCP TLM (TEPS2HSTMP)	At 1K TLM Rate: Best Case: 0.804 Worst Case: 0.805 At 4K TLM Rate: Best Case: 0.200 Worst Case: 0.201	At 1K TLM Rate: Best Case: 0.012 Worst Case: 0.012 At 4K TLM Rate: Best Case: 0.012 Worst Case: 0.012	At 1K TLM Rate: Best Case: 0.000 Worst Case: 16.000 At 4K TLM Rate: Best Case: 0.000 Worst Case: 4.000	At 1K TLM Rate: Best Case: 7.691 Worst Case: 8.191 At 4K TLM Rate: Best Case: 7.691 Worst Case: 8.191	At 1K TLM Rate: Best Case: 8.507 Worst Case: 25.008 At 4K TLM Rate: Best Case: 7.903 Worst Case: 12.404	
Mux 1 Electronics Temperature	0	81	TDF-to-SCP TLM (TE-MUX1ETMP) or Active Mux (1 or 2) Elec. Temp. after TDF RAM patch (TEMUX-ETMP)	At 1K TLM Rate: Best Case: 0.788 Worst Case: 0.789 At 4K TLM Rate: Best Case: 0.196 Worst Case: 0.197	At 1K TLM Rate: Best Case: 0.012 Worst Case: 0.012 At 4K TLM Rate: Best Case: 0.012 Worst Case: 0.012	At 1K TLM Rate: Best Case: 0.000 Worst Case: 16.000 At 4K TLM Rate: Best Case: 0.000 Worst Case: 4.000	At 1K TLM Rate: Best Case: 7.691 Worst Case: 8.191 At 4K TLM Rate: Best Case: 7.691 Worst Case: 8.191	At 1K TLM Rate: Best Case: 8.491 Worst Case: 24.992 At 4K TLM Rate: Best Case: 7.899 Worst Case: 12.400	
Mux 2 Electronics Temperature	0	83	TDF-to-SCP TLM (TE-MUX2ETMP) or CAL Lamp 2 current after TDF RAM patch (TE-CLAMP2I_P)	At 1K TLM Rate: Best Case: 0.772 Worst Case: 0.773 At 4K TLM Rate: Best Case: 0.192 Worst Case: 0.193	At 1K TLM Rate: Best Case: 0.012 Worst Case: 0.012 At 4K TLM Rate: Best Case: 0.012 Worst Case: 0.012	At 1K TLM Rate: Best Case: 0.000 Worst Case: 16.000 At 4K TLM Rate: Best Case: 0.000 Worst Case: 4.000	At 1K TLM Rate: Best Case: 7.691 Worst Case: 8.191 At 4K TLM Rate: Best Case: 7.691 Worst Case: 8.191	At 1K TLM Rate: Best Case: 8.475 Worst Case: 24.976 At 4K TLM Rate: Best Case: 7.895 Worst Case: 12.396	

TABLE C-1. PAYLOAD CORRECTION DATA LATENCIES RELATIVE TO PDF TIME CODE IN WIDEBAND DATA

DESCRIPTION	MAJOR FRAME	MINOR FRAME	DATA SOURCE	CASE 1: TDF-ORIGINATED DATA			CASE 2: FSW-ORIGINATED DATA	LATENCY FROM PC/D S/W BUFFERING AND PDF BUFFERING (SECS)	TOTAL LATENCY (SECS)
				LATENCY FROM DATA SAMPLING BY TDF TO LEVEL 10 INTERRUPT (SECS)	LATENCY FROM INTERRUPT TO DATA AVAILABILITY IN SUBCOM TABLE	LATENCY FROM TDF SAMPLING RATE (SECS)			
Mux 1 Power Supply Temperature	0	82	TDF-to-SCP TLM (TE-MUX1PST) or Active Mux (1 or 2) Power Supply Temp. after TDF RAM patch (TEMUXPST)	At 1K TLM Rate: Best Case: 0.780 Worst Case: 0.781	At 1K TLM Rate: Best Case: 0.012 Worst Case: 0.012	At 1K TLM Rate: Best Case: 0.000 Worst Case: 16.000	At 1K TLM Rate: Best Case: 7.691 Worst Case: 8.191	At 1K TLM Rate: Best Case: 8.483 Worst Case: 24.984	
				At 4K TLM Rate: Best Case: 0.194 Worst Case: 0.195	At 4K TLM Rate: Best Case: 0.012 Worst Case: 0.012	At 4K TLM Rate: Best Case: 0.000 Worst Case: 4.000	At 4K TLM Rate: Best Case: 7.691 Worst Case: 8.191	At 4K TLM Rate: Best Case: 7.897 Worst Case: 12.398	
Mux 2 Power Supply Temperature	1	81	TDF-to-SCP TLM (TE-MUX2PST) or CAL Lamp 1 Current afater TDF RAM patch (TE-CLAMP1_P)	At 1K TLM Rate: Best Case: 0.780 Worst Case: 0.781	At 1K TLM Rate: Best Case: 0.012 Worst Case: 0.012	At 1K TLM Rate: Best Case: 0.000 Worst Case: 16.000	At 1K TLM Rate: Best Case: 7.691 Worst Case: 8.191	At 1K TLM Rate: Best Case: 8.483 Worst Case: 24.984	
				At 4K TLM Rate: Best Case: 0.194 Worst Case: 0.195	At 4K TLM Rate: Best Case: 0.012 Worst Case: 0.012	At 4K TLM Rate: Best Case: 0.000 Worst Case: 4.000	At 4K TLM Rate: Best Case: 7.691 Worst Case: 8.191	At 4K TLM Rate: Best Case: 7.897 Worst Case: 12.398	
Pan Band Post Amplifier Temperature	2	46	TDF-to-SCP TLM (TEBPATMP)	At 1K TLM Rate: Best Case: 0.772 Worst Case: 0.773	At 1K TLM Rate: Best Case: 0.012 Worst Case: 0.012	At 1K TLM Rate: Best Case: 0.000 Worst Case: 16.000	At 1K TLM Rate: Best Case: 7.691 Worst Case: 8.191	At 1K TLM Rate: Best Case: 8.475 Worst Case: 24.976	
				At 4K TLM Rate: Best Case: 0.192 Worst Case: 0.193	At 4K TLM Rate: Best Case: 0.012 Worst Case: 0.012	At 4K TLM Rate: Best Case: 0.000 Worst Case: 4.000	At 4K TLM Rate: Best Case: 7.691 Worst Case: 8.191	At 4K TLM Rate: Best Case: 7.895 Worst Case: 12.396	

TABLE C-1. PAYLOAD CORRECTION DATA LATENCIES RELATIVE TO PDF TIME CODE IN WIDEBAND DATA

DESCRIPTION	MAJOR FRAME	MINOR FRAME	DATA SOURCE	CASE 1: TDF-ORIGINATED DATA			CASE 2: FSW-ORIGINATED DATA	LATENCY FROM PC/D S/W BUFFERING AND PDF BUFFERING (SECS)	TOTAL LATENCY (SECS)
				LATENCY FROM INTERRUPT TO DATA AVAIL-ABILITY IN SUBCOM TABLE	LATENCY FROM TDF SAMPLING RATE (SECS)	LATENCY FROM OTHER NON-PC/D FSW			
Primary Mirror Mask Temperature	2	41	TDF-to-SCP TLM (TE-PRIMTMP)	At 1K TLM Rate: Best Case: 0.812 Worst Case: 0.813	At 1K TLM Rate: Best Case: 0.012 Worst Case: 0.012	At 1K TLM Rate: Best Case: 0.000 Worst Case: 16.000	At 1K TLM Rate: Best Case: 7.691 Worst Case: 8.191	At 1K TLM Rate: Best Case: 8.515 Worst Case: 25.016	
Primary Mirror Temperature	2	40	TDF-to-SCP TLM (TE-PRIMRTMP)	At 1K TLM Rate: Best Case: 0.202 Worst Case: 0.203	At 4K TLM Rate: Best Case: 0.012 Worst Case: 0.012	At 4K TLM Rate: Best Case: 0.000 Worst Case: 4.000	At 4K TLM Rate: Best Case: 7.691 Worst Case: 8.191	At 4K TLM Rate: Best Case: 7.905 Worst Case: 12.406	
Scan-Line Corrector Temperature	2	24	TDF-to-SCP TLM (TESLCTMP)	At 1K TLM Rate: Best Case: 0.772 Worst Case: 0.773	At 1K TLM Rate: Best Case: 0.012 Worst Case: 0.012	At 1K TLM Rate: Best Case: 0.000 Worst Case: 16.000	At 1K TLM Rate: Best Case: 7.691 Worst Case: 8.191	At 1K TLM Rate: Best Case: 8.475 Worst Case: 24.976	
				At 4K TLM Rate: Best Case: 0.192 Worst Case: 0.193	At 4K TLM Rate: Best Case: 0.012 Worst Case: 0.012	At 4K TLM Rate: Best Case: 0.000 Worst Case: 4.000	At 4K TLM Rate: Best Case: 7.691 Worst Case: 8.191	At 4K TLM Rate: Best Case: 7.895 Worst Case: 12.396	
							At 4K TLM Rate: Best Case: 7.903 Worst Case: 12.404		

TABLE C-1. PAYLOAD CORRECTION DATA LATENCIES RELATIVE TO PDF TIME CODE IN WIDEBAND DATA

DESCRIPTION	MAJOR FRAME	MINOR FRAME	DATA SOURCE	CASE 1: TDF-ORIGINATED DATA			CASE 2: FSW-ORIGINATED DATA	LATENCY FROM PC/D S/W BUFFERING AND PDF BUFFERING (SECS)	TOTAL LATENCY (SECS)
				LATENCY FROM LEVEL 10 INTERRUPT TO DATA AVAIL-ABILITY IN SUBCOM TABLE	LATENCY FROM TDF SAMPLING RATE (SECS)	LATENCY FROM OTHER NON-PC/D FSW			
Secondary Mirror Mask Temperature	2	43	TDF-to-SCP TLM (TE-SECMRTMP)	<u>At 1K TLM Rate:</u> Best Case: 0.012 Worst Case: 0.012 <u>At 4K TLM Rate:</u> Best Case: 0.012 Worst Case: 0.012	<u>At 1K TLM Rate:</u> Best Case: 0.796 Worst Case: 0.797 <u>At 4K TLM Rate:</u> Best Case: 0.198 Worst Case: 0.199	<u>At 1K TLM Rate:</u> Best Case: 0.000 Worst Case: 16.000 <u>At 4K TLM Rate:</u> Best Case: 0.000 Worst Case: 4.000	<u>At 1K TLM Rate:</u> Best Case: 0.000 Worst Case: 0.000 <u>At 4K TLM Rate:</u> Best Case: 0.000 Worst Case: 0.000	<u>At 1K TLM Rate:</u> Best Case: 7.691 Worst Case: 8.191 <u>At 4K TLM Rate:</u> Best Case: 7.691 Worst Case: 8.191	<u>At 1K TLM Rate:</u> Best Case: 8.499 Worst Case: 25.000 <u>At 4K TLM Rate:</u> Best Case: 7.901 Worst Case: 12.402
Secondary Mirror Temperature	2	42	TDF-to-SCP TLM (TE-SECMRTMP)	<u>At 1K TLM Rate:</u> Best Case: 0.012 Worst Case: 0.012 <u>At 4K TLM Rate:</u> Best Case: 0.012 Worst Case: 0.012	<u>At 1K TLM Rate:</u> Best Case: 0.788 Worst Case: 0.789 <u>At 4K TLM Rate:</u> Best Case: 0.196 Worst Case: 0.197	<u>At 1K TLM Rate:</u> Best Case: 0.000 Worst Case: 16.000 <u>At 4K TLM Rate:</u> Best Case: 0.000 Worst Case: 4.000	<u>At 1K TLM Rate:</u> Best Case: 0.000 Worst Case: 0.000 <u>At 4K TLM Rate:</u> Best Case: 0.000 Worst Case: 0.000	<u>At 1K TLM Rate:</u> Best Case: 7.691 Worst Case: 8.191 <u>At 4K TLM Rate:</u> Best Case: 7.691 Worst Case: 8.191	<u>At 1K TLM Rate:</u> Best Case: 8.491 Worst Case: 24.992 <u>At 4K TLM Rate:</u> Best Case: 7.899 Worst Case: 12.400

TABLE C-1. PAYLOAD CORRECTION DATA LATENCIES RELATIVE TO PDF TIME CODE IN WIDEBAND DATA

DESCRIPTION	MAJOR FRAME	MINOR FRAME	DATA SOURCE	CASE 1: TDF-ORIGINATED DATA			CASE 2: FSW-ORIGINATED DATA	LATENCY FROM PC/D S/W BUFFERING AND PDF BUFFERING (SECS)	TOTAL LATENCY (SECS)
				LATENCY FROM LEVEL 10 INTERRUPT TO DATA AVAIL-ABILITY IN SUBCOM TABLE	LATENCY FROM TDF SAMPLING RATE (SECS)	LATENCY FROM OTHER NON-PC/D FSW			
Serial Word "A" Bit PS 2 Thermal Shutdown Enabled 0 PS 1 Thermal Shutdown Enabled 1 SMA +Z Heater Controller ON 2 SMA -Z Heater Controller ON 3 Spare 4 Shutter Fusible Link 5 Switch A Closed 6 Shutter Fusible Link 7 Switch B Closed 8 Shutter Fusible Link 9 Switch C Closed	2	31	TDF-to-SCP TLM (TETMEMA)	At 1K TLM Rate: Best Case: 1.999 Worst Case: 2.000 At 4K TLM Rate: Best Case: 0.499 Worst Case: 0.500	At 1K TLM Rate: Best Case: 0.012 Worst Case: 0.012 At 4K TLM Rate: Best Case: 0.012 Worst Case: 0.012	At 1K TLM Rate: Best Case: 0.000 Worst Case: 16.000 At 4K TLM Rate: Best Case: 0.000 Worst Case: 4.000	At 1K TLM Rate: Best Case: 7.691 Worst Case: 8.191 At 4K TLM Rate: Best Case: 7.691 Worst Case: 8.191	At 1K TLM Rate: Best Case: 9.702 Worst Case: 26.203 At 4K TLM Rate: Best Case: 8.202 Worst Case: 12.703	
Serial Word "B" Bit Band 1 ON 0 Band 2 ON 1 Band 3 ON 2 Band 4 ON 3 Band 5 ON 4 Band 6/MIR ON 5 Band 7 ON 6 Cold Stage Telemetry ON 7	2	32	TDF-to-SCP TLM (TETMEMB)	At 1K TLM Rate: Best Case: 1.999 Worst Case: 2.000 At 4K TLM Rate: Best Case: 0.499 Worst Case: 0.500	At 1K TLM Rate: Best Case: 0.012 Worst Case: 0.012 At 4K TLM Rate: Best Case: 0.012 Worst Case: 0.012	At 1K TLM Rate: Best Case: 0.000 Worst Case: 16.000 At 4K TLM Rate: Best Case: 0.000 Worst Case: 4.000	At 1K TLM Rate: Best Case: 7.691 Worst Case: 8.191 At 4K TLM Rate: Best Case: 7.691 Worst Case: 8.191	At 1K TLM Rate: Best Case: 9.702 Worst Case: 26.203 At 4K TLM Rate: Best Case: 8.202 Worst Case: 12.703	

TABLE C-1. PAYLOAD CORRECTION DATA LATENCIES RELATIVE TO PDF TIME CODE IN WIDEBAND DATA

				CASE 1: TDF-ORIGINATED DATA			CASE 2: FSW- ORIGINATED DATA			
DESCRIPTION	MAJOR FRAME	MINOR FRAME	DATA SOURCE	LATENCY FROM LEVEL 10 INTERRUPT TO DATA AVAIL- ABILITY IN SUBCOM TABLE	LATENCY FROM TDF SAMPLING RATE (SECS)	LATENCY FROM OTHER NON-PCD FSW	LATENCY FROM PCD S/W BUFFERING AND PDF BUFFERING (SECS)	TOTAL LATENCY (SECS)		
Serial Word "C" Bit Cooler Door Closed 0 Cooler Door Outgas Posi- tion 1 Cooler Door Full Open 2 Cooler Door Magnet ON3 Cooler Door Motor Drive ON 4 Cooler Door Fusible Link Switch A Closed 5 Cooler Door Fusible Link Switch B Closed 6 Cooler Door Fusible Link Switch C Closed 7	2	33	TDF-to-SCP TLM (TETMEMC)	At 1K TLM Rate: Best Case: 0.012 Worst Case: 0.012 At 4K TLM Rate: Best Case: 0.012 Worst Case: 0.012	At 1K TLM Rate: Best Case: 0.000 Worst Case: 16.000 At 4K TLM Rate: Best Case: 0.000 Worst Case: 4.000	At 1K TLM Rate: Best Case: 0.000 Worst Case: 0.000 At 4K TLM Rate: Best Case: 0.000 Worst Case: 0.000	At 1K TLM Rate: Best Case: 7.691 Worst Case: 8.191 At 4K TLM Rate: Best Case: 7.691 Worst Case: 8.191	At 1K TLM Rate: Best Case: 9.702 Worst Case: 26.203 At 4K TLM Rate: Best Case: 8.202 Worst Case: 12.703		
Serial Word "D" Bit Calibration Lamp 1 ON 0 Calibration Lamp 2 ON 1 Spare 2 Calibration Lamp 1 Back- up ON 3 Calibration Lamp 2 Back- up ON 4 Spare 5 Spare 6 Spare 7	2	34	TDF-to-SCP TLM (TETMEMD)	At 1K TLM Rate: Best Case: 0.012 Worst Case: 0.012 At 4K TLM Rate: Best Case: 0.012 Worst Case: 0.012	At 1K TLM Rate: Best Case: 0.000 Worst Case: 16.000 At 4K TLM Rate: Best Case: 0.000 Worst Case: 4.000	At 1K TLM Rate: Best Case: 0.000 Worst Case: 0.000 At 4K TLM Rate: Best Case: 0.000 Worst Case: 0.000	At 1K TLM Rate: Best Case: 7.691 Worst Case: 8.191 At 4K TLM Rate: Best Case: 7.691 Worst Case: 8.191	At 1K TLM Rate: Best Case: 9.702 Worst Case: 26.203 At 4K TLM Rate: Best Case: 8.202 Worst Case: 12.703		
Serial Word "E" Bit Band P ON 0 Spare 1 Blackbody Heater Con- troller ON 2 Blackbody T2 ON 3 Blackbody T3 ON 4 Blackbody Backup ON 5 SME 1 ON 6 SME 2 ON 7	2	35	TDF-to-SCP TLM (TETMEME)	At 1K TLM Rate: Best Case: 0.012 Worst Case: 0.012 At 4K TLM Rate: Best Case: 0.012 Worst Case: 0.012	At 1K TLM Rate: Best Case: 0.000 Worst Case: 16.000 At 4K TLM Rate: Best Case: 0.000 Worst Case: 4.000	At 1K TLM Rate: Best Case: 0.000 Worst Case: 0.000 At 4K TLM Rate: Best Case: 0.000 Worst Case: 0.000	At 1K TLM Rate: Best Case: 7.691 Worst Case: 8.191 At 4K TLM Rate: Best Case: 7.691 Worst Case: 8.191	At 1K TLM Rate: Best Case: 9.702 Worst Case: 26.203 At 4K TLM Rate: Best Case: 8.202 Worst Case: 12.703		

TABLE C-1. PAYLOAD CORRECTION DATA LATENCIES RELATIVE TO PDF TIME CODE IN WIDEBAND DATA

DESCRIPTION	MAJOR FRAME	MINOR FRAME	DATA SOURCE	CASE 1: TDF-ORIGINATED DATA			CASE 2: FSW-ORIGINATED DATA	LATENCY FROM PCD S/W BUFFERING AND PDF BUFFERING (SECS)	TOTAL LATENCY (SECS)
				LATENCY FROM DATA SAMPLING BY TDF TO LEVEL 10 INTERRUPT TO FSW (SECS)	LATENCY FROM LEVEL 10 INTERRUPT TO DATA AVAILABILITY IN SUBCOM TABLE	LATENCY FROM TDF SAMPLING RATE (SECS)			
Serial Word "F" Bit Baffle Heater Controller ON Baffle Heater Backup ON 1 Spare 2 Spare 3 Spare 4 Spare 5 Spare 6 Spare 7	2	36	TDF-to-SCP TLM (TETMEMF)	At 1K TLM Rate: Best Case: 1.999 Worst Case: 2.000 At 4K TLM Rate: Best Case: 0.499 Worst Case: 0.500	At 1K TLM Rate: Best Case: 0.012 Worst Case: 0.012 At 4K TLM Rate: Best Case: 0.012 Worst Case: 0.012	At 1K TLM Rate: Best Case: 0.000 Worst Case: 16.000 At 4K TLM Rate: Best Case: 0.000 Worst Case: 4.000	At 1K TLM Rate: Best Case: 7.691 Worst Case: 8.191 At 4K TLM Rate: Best Case: 7.691 Worst Case: 8.191	At 1K TLM Rate: Best Case: 9.702 Worst Case: 26.203 At 4K TLM Rate: Best Case: 8.202 Worst Case: 12.703	
Serial Word "G" Bit Scan Line Corrector 1 ON Scan Line Corrector 2 ON Calibration Shutter ON 2 Calibration Shutter Phase Error 3 Calibration Shutter Amplitude Error 4 Backup Shutter ON 5 Backup Shutter Phase Error 6 Backup Shutter Amplitude Error 7	2	37	TDF-to-SCP TLM (TETMEMG)	At 1K TLM Rate: Best Case: 2.999 Worst Case: 3.000 At 4K TLM Rate: Best Case: 0.749 Worst Case: 0.750	At 1K TLM Rate: Best Case: 0.012 Worst Case: 0.012 At 4K TLM Rate: Best Case: 0.012 Worst Case: 0.012	At 1K TLM Rate: Best Case: 0.000 Worst Case: 16.000 At 4K TLM Rate: Best Case: 0.000 Worst Case: 4.000	At 1K TLM Rate: Best Case: 7.691 Worst Case: 8.191 At 4K TLM Rate: Best Case: 7.691 Worst Case: 8.191	At 1K TLM Rate: Best Case: 10.702 Worst Case: 27.203 At 4K TLM Rate: Best Case: 8.452 Worst Case: 12.953	

TABLE C-1. PAYLOAD CORRECTION DATA LATENCIES RELATIVE TO PDF TIME CODE IN WIDEBAND DATA

DESCRIPTION	MAJOR FRAME	MINOR FRAME	DATA SOURCE	CASE 1: TDF-ORIGINATED DATA			CASE 2: FSW-ORIGINATED DATA	LATENCY FROM PCD S/W BUFFERING AND PDF BUFFERING (SECS)	TOTAL LATENCY (SECS)
				LATENCY FROM INTERRUPT TO DATA AVAILABILITY IN SUBCOM TABLE	LATENCY FROM SAMPLING BY TDF TO LEVEL 10 INTERRUPT TO FSW (SECS)	LATENCY FROM TDF SAMPLING RATE (SECS)			
Serial Word "H" Bit Cold Stage Heater Controller ON Cold Stage Outgas Heater Enabled Intermediate Stage Heater Controller ON Intermediate Stage Heater Enabled CFPA Heater Controller ON CFPA T2 Relay ON CFPA T3 Relay ON CFPA Telemetry ON	2	38	TDF-to-SCP TLM (TETMEMH)	At 1K TLM Rate: Best Case: 0.012 Worst Case: 0.012 At 4K TLM Rate: Best Case: 0.012 Worst Case: 0.012	At 1K TLM Rate: Best Case: 2.999 Worst Case: 3.000 At 4K TLM Rate: Best Case: 0.749 Worst Case: 0.750	At 1K TLM Rate: Best Case: 0.000 Worst Case: 16.000 At 4K TLM Rate: Best Case: 0.000 Worst Case: 4.000	At 1K TLM Rate: Best Case: 7.691 Worst Case: 8.191 At 4K TLM Rate: Best Case: 7.691 Worst Case: 8.191	At 1K TLM Rate: Best Case: 10.702 Worst Case: 27.203 At 4K TLM Rate: Best Case: 8.452 Worst Case: 12.953	
Serial Word "I" Bit DC Restore Normal Frame DC Restore Selected Telemetry Scaling ON SMA +Z Heater Enabled SMA -Z Heater Enabled Spare SME 1 Select SAM Spare Opto	2	39	TDF-to-SCP TLM (TETMEMI)	At 1K TLM Rate: Best Case: 0.012 Worst Case: 0.012 At 4K TLM Rate: Best Case: 0.012 Worst Case: 0.012	At 1K TLM Rate: Best Case: 2.999 Worst Case: 3.000 At 4K TLM Rate: Best Case: 0.749 Worst Case: 0.750	At 1K TLM Rate: Best Case: 0.000 Worst Case: 16.000 At 4K TLM Rate: Best Case: 0.000 Worst Case: 4.000	At 1K TLM Rate: Best Case: 7.691 Worst Case: 8.191 At 4K TLM Rate: Best Case: 7.691 Worst Case: 8.191	At 1K TLM Rate: Best Case: 10.702 Worst Case: 27.203 At 4K TLM Rate: Best Case: 8.452 Worst Case: 12.953	

TABLE C-1. PAYLOAD CORRECTION DATA LATENCIES RELATIVE TO PDF TIME CODE IN WIDEBAND DATA

DESCRIPTION	MAJOR FRAME	MINOR FRAME	DATA SOURCE	CASE 1: TDF-ORIGINATED DATA			CASE 2: FSW-ORIGINATED DATA	LATENCY FROM PCD S/W BUFFERING AND PDF BUFFERING (SECS)	TOTAL LATENCY (SECS)
				LATENCY FROM LEVEL 10 INTERRUPT TO DATA AVAIL-ABILITY IN SUBCOM TABLE	LATENCY FROM TDF SAMPLING RATE (SECS)	LATENCY FROM OTHER NON-PCD FSW			
Serial Word "J" Bit AEM Multiplexer 1 BAND 1 Gain State AEM Multiplexer 1 BAND 2 Gain State AEM Multiplexer 1 BAND 3 Gain State AEM Multiplexer 1 BAND 4 Gain State AEM Multiplexer 1 BAND 5 Gain State AEM Multiplexer 1 BAND 6 PRI Gain State AEM Multiplexer 1 BAND 7 Gain State AEM Multiplexer 1 BAND P Gain State	1	82	TDF-to-SCP TLM (TETMEMJ)	At 1K TLM Rate: Best Case: 0.012 Worst Case: 0.012	At 1K TLM Rate: Best Case: 0.000 Worst Case: 16.000	At 1K TLM Rate: Best Case: 0.000 Worst Case: 0.000	At 1K TLM Rate: Best Case: 7.691 Worst Case: 8.191	At 1K TLM Rate: Best Case: 10.702 Worst Case: 27.203	
Serial Word "K" Bit AEM Multiplexer 2 BAND 1 Gain State AEM Multiplexer 2 BAND 2 Gain State AEM Multiplexer 2 BAND 3 Gain State AEM Multiplexer 2 BAND 4 Gain State AEM Multiplexer 2 BAND 5 Gain State AEM Multiplexer 2 BAND 6 PRI Gain State AEM Multiplexer 2 BAND 7 Gain State AEM Multiplexer 2 BAND P Gain State	1	83	TDF-to-SCP TLM (TETMEMK)	At 1K TLM Rate: Best Case: 0.012 Worst Case: 0.012	At 1K TLM Rate: Best Case: 0.000 Worst Case: 16.000	At 1K TLM Rate: Best Case: 0.000 Worst Case: 0.000	At 1K TLM Rate: Best Case: 7.691 Worst Case: 8.191	At 1K TLM Rate: Best Case: 10.702 Worst Case: 27.203	

TABLE C-1. PAYLOAD CORRECTION DATA LATENCIES RELATIVE TO PDF TIME CODE IN WIDEBAND DATA

DESCRIPTION	MAJOR FRAME	MINOR FRAME	DATA SOURCE	CASE 1: TDF-ORIGINATED DATA			CASE 2: FSW-ORIGINATED DATA	LATENCY FROM PC/D S/W BUFFERING AND PDF BUFFERING (SECS)	TOTAL LATENCY (SECS)
				LATENCY FROM LEVEL 10 INTERRUPT TO DATA AVAIL-ABILITY IN SUBCOM TABLE	LATENCY FROM TDF SAMPLING RATE (SECS)	LATENCY FROM OTHER NON-PC/D FSW			
Serial Word "L" Bit Cooler Door Direction (1=Open) Cooler Door Move Enable	2	81	TDF-to-SCP TLM (TETMEML)	At 1K TLM Rate: Best Case: 0.012 Worst Case: 0.012	At 1K TLM Rate: Best Case: 0.000 Worst Case: 16.000	At 1K TLM Rate: Best Case: 0.000 Worst Case: 0.000	At 1K TLM Rate: Best Case: 7.691 Worst Case: 8.191	At 1K TLM Rate: Best Case: 10.702 Worst Case: 27.203	
1 FAC Failsafe Static Motor Power ON 2 FAC Primary Static Motor Power ON 3 FAC Primary Motor Pow- er ON 4 FAC Failsafe Motor Pow- er ON 5 FAC Primary Controller Direction 6 FAC Failsafe Controller Direction 7				At 4K TLM Rate: Best Case: 0.012 Worst Case: 0.012	At 4K TLM Rate: Best Case: 0.000 Worst Case: 4.000	At 4K TLM Rate: Best Case: 0.000 Worst Case: 0.000	At 4K TLM Rate: Best Case: 7.691 Worst Case: 8.191	At 4K TLM Rate: Best Case: 8.452 Worst Case: 12.953	
Serial Word "M" Bit Mux 1/2 Analog Power Selected 0 Mux 1/2 Digital Power Se- lected 1 Spare 2 Spare 3 FAC Primary Controller Single-Step Sizes 4 FAC Failsafe Controller single-Step Sizes 5 FAC Primary Controller Power ON 6 FAC Failsafe Controller Power ON 7	2	82	TDF-to-SCP TLM (TETMEMM)	At 1K TLM Rate: Best Case: 5.999 Worst Case: 6.000	At 1K TLM Rate: Best Case: 0.000 Worst Case: 16.000	At 1K TLM Rate: Best Case: 0.000 Worst Case: 0.000	At 1K TLM Rate: Best Case: 7.691 Worst Case: 8.191	At 1K TLM Rate: Best Case: 13.702 Worst Case: 30.203	
				At 4K TLM Rate: Best Case: 1.499 Worst Case: 1.500	At 4K TLM Rate: Best Case: 0.000 Worst Case: 4.000	At 4K TLM Rate: Best Case: 0.000 Worst Case: 0.000	At 4K TLM Rate: Best Case: 7.691 Worst Case: 8.191	At 4K TLM Rate: Best Case: 9.202 Worst Case: 13.703	

TABLE C-1. PAYLOAD CORRECTION DATA LATENCIES RELATIVE TO PDF TIME CODE IN WIDEBAND DATA

DESCRIPTION	MAJOR FRAME	MINOR FRAME	DATA SOURCE	CASE 1: TDF-ORIGINATED DATA			CASE 2: FSW-ORIGINATED DATA	LATENCY FROM PC/D S/W BUFFERING AND PDF BUFFERING (SECS)	TOTAL LATENCY (SECS)
				LATENCY FROM DATA SAMPLING BY TDF TO LEVEL 10 INTERRUPT TO FSW (SECS)	LATENCY FROM INTERRUPT TO DATA AVAILABILITY IN SUBCOM TABLE	LATENCY FROM TDF SAMPLING RATE (SECS)			
Serial Word "N" Bit AEM Multiplexer 1 ON 0 AEM Multiplexer 2 ON 1 AEM Multiplexer 1 MDE ON Status 2 AEM Multiplexer 2 MDE ON Status 3 AEM Multiplexer 1 Band 6 RDT Gain State 4 AEM Multiplexer 2 Band 6 RDT Gain State 5 AEM Multiplexer 1 Data Priority Selected 6 AEM Multiplexer 2 Data Priority Selected 7	2	83	TDF-to-SCP TLM (TETMEMN)	At 1K TLM Rate: Best Case: 5.999 Worst Case: 6.000 At 4K TLM Rate: Best Case: 1.499 Worst Case: 1.500	At 1K TLM Rate: Best Case: 0.012 Worst Case: 0.012 At 4K TLM Rate: Best Case: 0.012 Worst Case: 0.012	At 1K TLM Rate: Best Case: 0.000 Worst Case: 16.000 At 4K TLM Rate: Best Case: 0.000 Worst Case: 4.000	At 1K TLM Rate: Best Case: 7.691 Worst Case: 8.191 At 4K TLM Rate: Best Case: 7.691 Worst Case: 8.191	At 1K TLM Rate: Best Case: 13.702 Worst Case: 30.203 At 4K TLM Rate: Best Case: 9.202 Worst Case: 13.703	
Serial Word "P" Bit FAC Stow Position Switch PRI 0 FAC Stow Position Switch RDT 1 FAC Calibration Position Switch PRI 2 FAC Calibration Position Switch RDT 3 FAC Calibration/Stow Move ON Status PRI 4 FAC Calibration/Stow Move ON Status RDT 5 FAC Single-Step Move ON Status PRI 6 FAC Single-Step Move ON Status RDT 7	2	84	TDF-to-SCP TLM (TETMEMP)	At 1K TLM Rate: Best Case: 5.999 Worst Case: 6.000 At 4K TLM Rate: Best Case: 1.499 Worst Case: 1.500	At 1K TLM Rate: Best Case: 0.012 Worst Case: 0.012 At 4K TLM Rate: Best Case: 0.012 Worst Case: 0.012	At 1K TLM Rate: Best Case: 0.000 Worst Case: 16.000 At 4K TLM Rate: Best Case: 0.000 Worst Case: 4.000	At 1K TLM Rate: Best Case: 7.691 Worst Case: 8.191 At 4K TLM Rate: Best Case: 7.691 Worst Case: 8.191	At 1K TLM Rate: Best Case: 13.702 Worst Case: 30.203 At 4K TLM Rate: Best Case: 9.202 Worst Case: 13.703	

TABLE C-1. PAYLOAD CORRECTION DATA LATENCIES RELATIVE TO PDF TIME CODE IN WIDEBAND DATA

DESCRIPTION	MAJOR FRAME	MINOR FRAME	DATA SOURCE	CASE 1: TDF-ORIGINATED DATA			CASE 2: FSW-ORIGINATED DATA	LATENCY FROM PCD S/W BUFFERING AND PDF BUFFERING (SECS)	TOTAL LATENCY (SECS)
				LATENCY FROM LEVEL 10 INTERRUPT TO DATA AVAILABILITY IN SUBCOM TABLE	LATENCY FROM DATA SAMPLING BY TDF TO LEVEL 10 INTERRUPT TO FSW (SECS)	LATENCY FROM TDF SAMPLING RATE (SECS)			
Serial Word "Q" Bit FAC Pull-Pin Heater 1 ON FAC Pull-Pin Heater 2 ON FAC Pull-Pin Heater Power Enable PRI FAC Pull-Pin Heater Power FAC Pull-Pin Retracted Position Switch PRI FAC Pull-Pin Retracted Position Switch RDT FAC Pull-Pin Fully Retracted Position Switch PRI FAC Pull-Pin Fully Retracted Position Switch RDT	3	81	TDF-to-SCP TLM (TETMEMQ)	At 1K TLM Rate: Best Case: 5.999 Worst Case: 6.000 At 4K TLM Rate: Best Case: 1.499 Worst Case: 1.500	At 1K TLM Rate: Best Case: 0.012 Worst Case: 0.012 At 4K TLM Rate: Best Case: 0.012 Worst Case: 0.012	At 1K TLM Rate: Best Case: 0.000 Worst Case: 16.000 At 4K TLM Rate: Best Case: 0.000 Worst Case: 4.000	At 1K TLM Rate: Best Case: 7.691 Worst Case: 8.191 At 4K TLM Rate: Best Case: 7.691 Worst Case: 8.191	At 1K TLM Rate: Best Case: 13.702 Worst Case: 30.203 At 4K TLM Rate: Best Case: 9.202 Worst Case: 13.703	
Serial Word "R" Bit FAC Primary CW Rotation Switch Status 0 FAC Primary CCW Rotation Switch Status 1 FAC Redundant CW Rotation Switch Status 2 FAC Redundant CCW Rotation Switch Status 3 Spare 4 Spare 5 Spare 6 Spare 7	3	82	TDF-to-SCP TLM (TETMEMR)	At 1K TLM Rate: Best Case: 5.999 Worst Case: 6.000 At 4K TLM Rate: Best Case: 1.499 Worst Case: 1.500	At 1K TLM Rate: Best Case: 0.012 Worst Case: 0.012 At 4K TLM Rate: Best Case: 0.012 Worst Case: 0.012	At 1K TLM Rate: Best Case: 0.000 Worst Case: 16.000 At 4K TLM Rate: Best Case: 0.000 Worst Case: 4.000	At 1K TLM Rate: Best Case: 7.691 Worst Case: 8.191 At 4K TLM Rate: Best Case: 7.691 Worst Case: 8.191	At 1K TLM Rate: Best Case: 13.702 Worst Case: 30.203 At 4K TLM Rate: Best Case: 9.202 Worst Case: 13.703	

TABLE C-1. PAYLOAD CORRECTION DATA LATENCIES RELATIVE TO PDF TIME CODE IN WIDEBAND DATA

DESCRIPTION	MAJOR FRAME	MINOR FRAME	DATA SOURCE	CASE 1: TDF-ORIGINATED DATA			CASE 2: FSW-ORIGINATED DATA	LATENCY FROM PC/D S/W BUFFERING AND PDF BUFFERING (SECS)	TOTAL LATENCY (SECS)
				LATENCY FROM LEVEL 10 INTERRUPT TO DATA AVAIL-ABILITY IN SUBCOM TABLE	LATENCY FROM TDF SAMPLING RATE (SECS)	LATENCY FROM OTHER NON-PC/D FSW			
Serial Word "S" Bit Command Reject, Enable 1 P Command Reject, Enable 2 P Command Reject, Enable 3 P Command Reject, Enable 4 P Command Reject, Enable 1 R Command Reject, Enable 2 R Command Reject, Enable 3 R Command Reject, Enable 4 R	3	83	TDF-to-SCP TLM (TETMEMS)	LATENCY FROM LEVEL 10 INTERRUPT TO DATA AVAIL-ABILITY IN SUBCOM TABLE At 1K TLM Rate: Best Case: 0.012 Worst Case: 0.012 At 4K TLM Rate: Best Case: 0.012 Worst Case: 0.012	LATENCY FROM TDF SAMPLING RATE (SECS) At 1K TLM Rate: Best Case: 0.000 Worst Case: 16.000 At 4K TLM Rate: Best Case: 0.000 Worst Case: 4.000	LATENCY FROM OTHER NON-PC/D FSW At 1K TLM Rate: Best Case: 0.000 Worst Case: 0.000 At 4K TLM Rate: Best Case: 0.000 Worst Case: 0.000	LATENCY FROM PC/D S/W BUFFERING AND PDF BUFFERING (SECS) At 1K TLM Rate: Best Case: 7.691 Worst Case: 8.191 At 4K TLM Rate: Best Case: 7.691 Worst Case: 8.191	TOTAL LATENCY (SECS) At 1K TLM Rate: Best Case: 13.702 Worst Case: 30.203 At 4K TLM Rate: Best Case: 9.202 Worst Case: 13.703	
Silicon Focal-Plane Assembly Temp.	2	17	TDF-to-SCP TLM (TESFPATMP)	LATENCY FROM LEVEL 10 INTERRUPT TO DATA AVAIL-ABILITY IN SUBCOM TABLE At 1K TLM Rate: Best Case: 0.012 Worst Case: 0.012 At 4K TLM Rate: Best Case: 0.012 Worst Case: 0.012	LATENCY FROM TDF SAMPLING RATE (SECS) At 1K TLM Rate: Best Case: 0.000 Worst Case: 16.000 At 4K TLM Rate: Best Case: 0.000 Worst Case: 4.000	LATENCY FROM OTHER NON-PC/D FSW At 1K TLM Rate: Best Case: 0.000 Worst Case: 0.000 At 4K TLM Rate: Best Case: 0.000 Worst Case: 0.000	LATENCY FROM PC/D S/W BUFFERING AND PDF BUFFERING (SECS) At 1K TLM Rate: Best Case: 7.691 Worst Case: 8.191 At 4K TLM Rate: Best Case: 7.691 Worst Case: 8.191	TOTAL LATENCY (SECS) At 1K TLM Rate: Best Case: 8.483 Worst Case: 24.984 At 4K TLM Rate: Best Case: 7.897 Worst Case: 12.398	

TABLE C-1. PAYLOAD CORRECTION DATA LATENCIES RELATIVE TO PDF TIME CODE IN WIDEBAND DATA

DESCRIPTION	MAJOR FRAME	MINOR FRAME	DATA SOURCE	CASE 1: TDF-ORIGINATED DATA			CASE 2: FSW-ORIGINATED DATA	LATENCY FROM PCD S/W BUFFERING AND PDF BUFFERING (SECS)	TOTAL LATENCY (SECS)
				LATENCY FROM LEVEL 10 INTERRUPT TO DATA AVAILABILITY IN SUBCOM TABLE	LATENCY FROM DATA SAMPLING BY TDF TO LEVEL 10 INTERRUPT TO FSW (SECS)	LATENCY FROM INTERRUPT TO TDF SAMPLING RATE (SECS)			
Spacecraft CPU MODE	3	84	ACSDEF CPU MODE	N/A	N/A	N/A	<u>At 1K TLM Rate:</u> Best Case: 0.400 Worst Case: 0.400 <u>At 4K TLM Rate:</u> Best Case: 0.400 Worst Case: 0.400	<u>At 1K TLM Rate:</u> Best Case: 8.091 Worst Case: 8.591 <u>At 4K TLM Rate:</u> Best Case: 8.091 Worst Case: 8.591	
SV Clock Drift (Accel)	0	40-41	EXCDEF ACCEL	N/A	N/A	N/A	<u>At 1K TLM Rate:</u> Best Case: 0.000 Worst Case: 0.500 <u>At 4K TLM Rate:</u> Best Case: 0.000 Worst Case: 0.500	<u>At 1K TLM Rate:</u> Best Case: 7.691 Worst Case: 8.691 <u>At 4K TLM Rate:</u> Best Case: 7.691 Worst Case: 8.691	
SV Clock Drift (Bias)	0	36-37	EXCDEF GRND/CLKBI AS	N/A	N/A	N/A	<u>At 1K TLM Rate:</u> Best Case: 0.000 Worst Case: 0.500 <u>At 4K TLM Rate:</u> Best Case: 0.000 Worst Case: 0.500	<u>At 1K TLM Rate:</u> Best Case: 7.691 Worst Case: 8.691 <u>At 4K TLM Rate:</u> Best Case: 7.691 Worst Case: 8.691	

TABLE C-1. PAYLOAD CORRECTION DATA LATENCIES RELATIVE TO PDF TIME CODE IN WIDEBAND DATA

DESCRIPTION	MAJOR FRAME	MINOR FRAME	DATA SOURCE	CASE 1: TDF-ORIGINATED DATA			CASE 2: FSW-ORIGINATED DATA	LATENCY FROM PCD S/W BUFFERING AND PDF BUFFERING (SECS)	TOTAL LATENCY (SECS)
				LATENCY FROM LEVEL 10 INTERRUPT TO DATA AVAIL-ABILITY IN SUBCOM TABLE	LATENCY FROM TDF TO LEVEL 10 INTERRUPT TO FSW (SECS)	LATENCY FROM TDF SAMPLING RATE (SECS)			
SV Clock Drift (Rate)	0	38-39	EXCDEF. DRIFT	N/A	N/A	N/A	<u>At 1K TLM Rate:</u> Best Case: 7.691 Worst Case: 8.691 <u>At 4K TLM Rate:</u> Best Case: 7.691 Worst Case: 8.691	<u>At 1K TLM Rate:</u> Best Case: 7.691 Worst Case: 8.691 <u>At 4K TLM Rate:</u> Best Case: 7.691 Worst Case: 8.691	
SV Clock Update Time	0	28-33	EXCDEF. TCORUP	N/A	N/A	N/A	<u>At 1K TLM Rate:</u> Best Case: 0.000 Worst Case: 0.500 <u>At 4K TLM Rate:</u> Best Case: 0.000 Worst Case: 0.500	<u>At 1K TLM Rate:</u> Best Case: 7.691 Worst Case: 8.691 <u>At 4K TLM Rate:</u> Best Case: 7.691 Worst Case: 8.691	

TABLE C-1. PAYLOAD CORRECTION DATA LATENCIES RELATIVE TO PDF TIME CODE IN WIDEBAND DATA

DESCRIPTION	MAJOR FRAME	MINOR FRAME	DATA SOURCE	CASE 1: TDF-ORIGINATED DATA			CASE 2: FSW-ORIGINATED DATA	LATENCY FROM PC/D S/W BUFFERING AND PDF BUFFERING (SECS)	TOTAL LATENCY (SECS)
				LATENCY FROM LEVEL 10 INTERRUPT TO DATA AVAIL-ABILITY IN SUBCOM TABLE	LATENCY FROM TDF TO LEVEL 10 INTERRUPT TO FSW (SECS)	LATENCY FROM TDF SAMPLING RATE (SECS)			
Telescope Baseplate Temperature	2	45	TDF-to-SCP TLM (TE-TELBPTMP)	At 1K TLM Rate: Best Case: 0.012 Worst Case: 0.012	At 1K TLM Rate: Best Case: 0.780 Worst Case: 0.781	At 1K TLM Rate: Best Case: 0.000 Worst Case: 16.000	At 1K TLM Rate: Best Case: 7.691 Worst Case: 8.191	At 1K TLM Rate: Best Case: 8.483 Worst Case: 24.984	
Telescope Housing Temperature	2	44	TDF-to-SCP TLM (TETELHTMP)	At 4K TLM Rate: Best Case: 0.194 Worst Case: 0.195	At 4K TLM Rate: Best Case: 0.772 Worst Case: 0.773	At 4K TLM Rate: Best Case: 0.000 Worst Case: 4.000	At 4K TLM Rate: Best Case: 7.691 Worst Case: 8.191	At 4K TLM Rate: Best Case: 7.897 Worst Case: 12.398	
				At 1K TLM Rate: Best Case: 0.012 Worst Case: 0.012	At 1K TLM Rate: Best Case: 0.000 Worst Case: 16.000	At 1K TLM Rate: Best Case: 0.000 Worst Case: 0.000	At 1K TLM Rate: Best Case: 7.691 Worst Case: 8.191	At 1K TLM Rate: Best Case: 8.475 Worst Case: 24.976	
				At 4K TLM Rate: Best Case: 0.012 Worst Case: 0.012	At 4K TLM Rate: Best Case: 0.192 Worst Case: 0.193	At 4K TLM Rate: Best Case: 0.000 Worst Case: 4.000	At 4K TLM Rate: Best Case: 7.691 Worst Case: 8.192	At 4K TLM Rate: Best Case: 7.895 Worst Case: 12.396	